

---

RS-232/422/485  
*Multi-Interface Industrial  
Ethernet Serial Servers*  
Models: ESR901, ESR902, ESR904





**International Headquarters**

B&B Electronics Mfg. Co. Inc.  
707 Dayton Road  
Ottawa, IL 61350 USA

**Phone** (815) 433-5100 -- **General Fax** (815) 433-5105

Website: [www.bb-elec.com](http://www.bb-elec.com)

**Sales** e-mail: [orders@bb-elec.com](mailto:orders@bb-elec.com) -- **Fax** (815) 433-5109

**Technical Support** e-mail: [support@bb.elec.com](mailto:support@bb.elec.com) -- **Fax** (815) 433-5104

**European Headquarters**

B&B Electronics Ltd.  
Westlink Commercial Park  
Oranmore, Co. Galway, Ireland

**Phone** +353 91-792444 -- **Fax** +353 91-792445

Website: [www.bb-europe.com](http://www.bb-europe.com)

**Sales** e-mail: [sales@bb-europe.com](mailto:sales@bb-europe.com)

**Technical Support** e-mail: [support@bb-europe.com](mailto:support@bb-europe.com)

© B&B Electronics – April 2005

---

Manual Documentation Number: ESR90x-1705m

B&B Electronics Mfg Co Inc – 707 Dayton Rd - Ottawa IL 61350 - Ph 815-433-5100 - Fax 815-433-5104 – [www.bb-elec.com](http://www.bb-elec.com)  
B&B Electronics Ltd – Westlink Commercial Park – Oranmore, Galway, Ireland – Ph +353 91-792444 – Fax +353 91-792445 – [www.bb-europe.com](http://www.bb-europe.com)

---

© 2005 B&B Electronics. No part of this publication may be reproduced or transmitted in any form or by any means, electronic or mechanical, including photography, recording, or any information storage and retrieval system without written consent. Information in this manual is subject to change without notice, and does not represent a commitment on the part of B&B Electronics.

B&B Electronics shall not be liable for incidental or consequential damages resulting from the furnishing, performance, or use of this manual.

All brand names used in this manual are the registered trademarks of their respective owners. The use of trademarks or other designations in this publication is for reference purposes only and does not constitute an endorsement by the trademark holder.

---

Manual Documentation Number: ESR90x-1705m

B&B Electronics Mfg Co Inc - 707 Dayton Rd - Ottawa IL 61350 - Ph 815-433-5100 - Fax 815-433-5104 - [www.bb-elec.com](http://www.bb-elec.com)  
B&B Electronics Ltd - Westlink Commercial Park - Oranmore, Galway, Ireland - Ph +353 91-792444 - Fax +353 91-792445 - [www.bb-europe.com](http://www.bb-europe.com)

# Table of Contents

<b>CHAPTER 1: INTRODUCTION.....</b>	<b>1</b>
FEATURES.....	1
COMMUNICATION MODES .....	3
<i>Direct IP Mode</i> .....	3
<i>Virtual COM Mode</i> .....	3
<i>Paired Mode</i> .....	3
<i>Heart Beat</i> .....	4
SERIAL SERVER QUICK START GUIDE .....	5
<i>Hardware Setup</i> .....	5
<i>Software Installation</i> .....	5
<i>Serial Server Configuration</i> .....	6
<i>Install Virtual COM Ports on PC</i> .....	7
<i>Check Communications</i> .....	7
<b>CHAPTER 2: MAKING THE HARDWARE CONNECTIONS .....</b>	<b>9</b>
PACKAGE CHECKLIST .....	9
ESR90X INDICATORS, SWITCHES AND CONNECTORS .....	10
<i>Indicators</i> .....	10
<i>Switches</i> .....	10
<i>Connectors</i> .....	10
SERIAL SERVER/PORT OPERATIONAL MODES .....	11
<i>Default Mode</i> .....	12
<i>Console Mode</i> .....	12
<i>Upgrade Mode</i> .....	12
<i>RS-232 Mode</i> .....	12
<i>RS-422 Mode</i> .....	13
<i>RS-485H Mode</i> .....	13
<i>RS-485F Mode</i> .....	13
<i>RS-485 Receiver Biasing</i> .....	13
<b>CHAPTER 3: INSTALLING THE VLINX SOFTWARE.....</b>	<b>19</b>
SOFTWARE INSTALLATION.....	19
<i>Automatic Installation</i> .....	19
<i>Manual Installation</i> .....	19
<i>Updating an Existing Installation</i> .....	21
<i>Opening the ESP Manager</i> .....	22

<b>CHAPTER 4: USING ESP MANAGER.....</b>	<b>23</b>
HARDWARE SETUP .....	23
SOFTWARE SETUP.....	24
SOFTWARE OVERVIEW .....	25
<i>Menus</i> .....	25
<i>Server Icons Pane</i> .....	27
<i>Serial Server / Virtual COM Lists</i> .....	27
<i>Status Bar</i> .....	28
SEARCH FOR SERVERS .....	28
CONFIGURE SERVER PROPERTIES .....	29
<b>CHAPTER 5: CONFIGURING THE SERIAL SERVER PROPERTIES.....</b>	<b>31</b>
DESCRIPTION OF THE SERVER PROPERTIES .....	32
<i>Server Name</i> .....	32
<i>Serial Number</i> .....	32
<i>Password</i> .....	32
<i>DHCP</i> .....	32
<i>IP Address</i> .....	33
<i>Netmask</i> .....	34
<i>Gateway</i> .....	34
<i>MAC Address</i> .....	34
<i>Version &amp; Date</i> .....	34
<i>Link Status</i> .....	34
<i>Server Serial Port</i> .....	34
<i>Baud Rate</i> .....	34
<i>Data/Parity/Stop</i> .....	34
<i>Flow Control</i> .....	35
<i>TCP/UDP Protocol</i> .....	35
<i>Serial Timeout</i> .....	36
<i>TCP Alive Timeout</i> .....	36
<i>Connection Mode</i> .....	36
<i>Delimiter HEX 1 and Delimiter HEX 2</i> .....	36
<i>Force Transmit</i> .....	37
<i>Port Status</i> .....	37
<i>TCP/UDP Port</i> .....	37
<i>Serial Port Mode</i> .....	37
<i>Connection At</i> .....	38
<i>Max Connection</i> .....	38
<i>Remote IP Address</i> .....	38
<i>Update/Save</i> .....	39
<b>CHAPTER 6: INSTALLING VIRTUAL COM PORTS .....</b>	<b>41</b>
VIRTUAL COM PORT INSTALLATION .....	41

---

MATCHING THE SERIAL SERVER AND VIRTUAL COM PORT SETTINGS .....	44
<b>CHAPTER 7: REMOVING VIRTUAL COM PORTS.....</b>	<b>47</b>
REMOVING THE VIRTUAL COM PORT WITH ESP MANAGER .....	47
REMOVING THE VIRTUAL COM PORT USING DEVICE MANAGER .....	48
<b>CHAPTER 8: UPGRADING THE SERIAL SERVER FIRMWARE.....</b>	<b>51</b>
DOWNLOADING THE FIRMWARE .....	51
UPGRADING VIA ESP MANAGER.....	51
<i>Preparing the Software</i> .....	51
<i>Upgrading the Firmware</i> .....	52
<b>CHAPTER 9: USING CONSOLE MODE .....</b>	<b>53</b>
CONSOLE MODE SETUP .....	53
<i>Navigating the Configuration Menus</i> .....	54
<i>Using a Password</i> .....	55
<b>CHAPTER 10: USING THE WEB SERVER .....</b>	<b>57</b>
SETTING SERVER PROPERTIES .....	57
<b>CHAPTER 11: USING TELNET.....</b>	<b>61</b>
CONFIGURATION USING TELNET .....	61
<i>Navigating the Configuration Menu</i> .....	63
<b>CHAPTER 12: ESR90X TECHNICAL DATA.....</b>	<b>65</b>
<b>APPENDIX A: RS-232 CONNECTIONS.....</b>	<b>70</b>
SERIAL SERVER DB-9 PIN-OUTS IN RS-232 MODE.....	70
ESR901 TERMINAL BLOCK PIN-OUT IN RS-232 MODE .....	71
<b>APPENDIX B: RS-422/485 CONNECTIONS.....</b>	<b>72</b>
ESR90X DB-9 PIN-OUT IN RS-422 MODE .....	72
ESR901 TERMINAL BLOCK PIN-OUT IN RS-422 MODE .....	73
<b>APPENDIX C: RS-485 CONNECTIONS.....</b>	<b>74</b>
ESR90X DB-9 PIN-OUT IN RS-485H (TWO-WIRE, HALF DUPLEX) MODE.....	74
ESR90X DB-9 PIN-OUT IN RS-485F (FOUR-WIRE, FULL DUPLEX) MODE .....	75
ESR901 TERMINAL BLOCK PIN-OUT IN RS-485F (FOUR-WIRE, FULL DUPLEX) MODE .....	76
<b>APPENDIX D: NETWORK CONNECTIONS.....</b>	<b>77</b>
STANDARD ETHERNET CABLE RJ-45 PIN-OUT.....	77
CROSSOVER ETHERNET CABLE RJ-45 PIN-OUT .....	78

## Chapter 1: INTRODUCTION

**VLINX ESR90x Industrial Ethernet Serial Servers** allow connection of RS-232, RS-422 or RS-485 devices to an Ethernet network. The serial ports can be accessed over a LAN/WAN using **Direct IP Mode**, **Virtual COM Port**, or **Paired Mode** connections. The 10/100 Mbps Ethernet connection auto-selects 10BaseT or 100BaseTX and indicates the type of connection with a bi-color link light. ESR90x serial servers are built for use in industrial environments, featuring an IP30, approved slim line DIN rail mountable case. They operate from a range of AC or DC power supply voltages, support redundant DC power and feature terminal block power connectors.

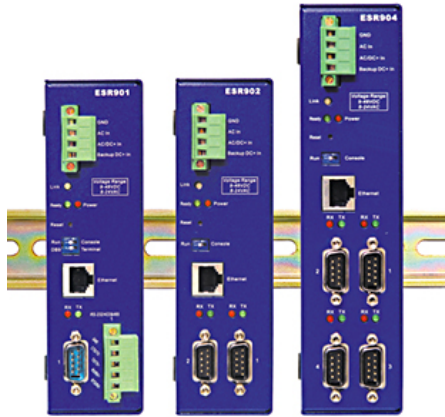

Figure 1. VLINX ESR90x Ethernet Serial Servers

### Features

- **Multi-interface serial ports**
  - The ESR901 features one multi-interface serial port and the choice of standard DB-9M or removable terminal block connections (switch selectable)
  - The ESR902 features two multi-interface serial ports
  - The ESR904 features four multi-interface serial ports

- All ports are software selectable as RS-232, RS-422, RS-485 full duplex or RS-485 half duplex interfaces
- For all models Port 1 is software, or DIP switch selectable for Console Mode operation (configuration via direct serial connection)
- **Slim line DIN rail mountable case**
- **Accepts AC or DC power over a wide volt range**
- **Redundant DC power supply input**
- **10/100 Mbps Ethernet** with Auto Selection
- **LAN and WAN Communications**
- **TCP or UDP Client or Server operation** - configurable
- **Software Support** - Windows 98/ME/2000/XP or NT 4.0
- **Firmware Upload** for future revisions/upgrades
- **Configuration** of Ethernet and serial port settings can be accomplished using any of four methods:
  - **VLINX ESP Manager Software for Windows** allows configuration via a network connection or directly from the Ethernet port of a computer (using an Ethernet crossover cable).
  - **Web Server** allows configuration via the network using a web browser.
  - **Telnet** allows configuration via the network by accessing the setup configuration menu.
  - **Console Mode** allows configuration through an RS-232 serial port in using a VT100 Terminal Emulation program and an RS-232 crossover cable.
- **Virtual COM Driver Software for Windows** - installs virtual COM ports, viewable in the Windows Device Manager under **Ports (COM & LPT)**. Virtual COM port provides access to any of the ports on the **Serial Server**, like any other serial port (legacy, PCI, USB or PCMCIA) on the computer. Any program running on the computer and using Windows-based COM ports can access the serial devices attached to the **Serial Server**. The LAN becomes transparent to the serial device and the software running on the PC.
- **Heart Beat Connection** - selectable protocol ensures reliable communications in Virtual COM Port or Paired Connection modes. This feature restores the connections if communications are temporarily lost at either end due to loss of power or the Ethernet connection.

## Communication Modes

The **ESR90x Serial servers** enable communication with serial devices over a LAN or WAN. Serial devices no longer are limited to a physical connection to the PC COM port. They can be installed anywhere on the LAN using TCP/IP or UDP/IP communications. This allows traditional Windows PC software access to serial devices anywhere on the LAN/WAN network.

### Direct IP Mode

**Direct IP** connections allow applications using TCP/IP or UDP/IP socket programs to communicate with the asynchronous serial ports on the serial server. In this type of application the serial server is configured as a TCP or UDP server. The socket program running on the PC establishes a communication connection with the **Serial Server**. The data is sent directly to and from the serial port on the server. When using UDP protocol the server can be configured to broadcast data to and receive data from multiple IP addresses.

### Virtual COM Mode

**Install Virtual COM Mode** allows the user to add a driver, to provide a virtual COM port on the computer. The new COM port shows up in the Device Manager. Windows programs using standard Windows API calls are able to interface to virtual COM ports. When a program on the PC opens the new COM port, it communicates with the remote serial device connected to one of the ports on the **Serial Server**.

After connection, the LAN is transparent to the program and serial device. Applications are able to work just as if the serial device is connected directly to a physical COM port on the computer. The virtual COM port software converts the application's data into IP packets, sends it across the network to the **Serial Server**, which converts the IP packet back to serial data and sends the data out a serial port located on the **Serial Server**.

To use this mode, the **Serial Server** must be set to either TCP/server or UDP/server with a designated communication port number. The virtual COM driver is the TCP or UDP client.

### Paired Mode

**Paired Mode** is also called *serial tunneling*. In this mode any two serial devices that can communicate with a serial link will be able to communicate using two **Serial Servers** and the LAN.

Two **Serial Servers** are connected to a network, one configured as a TCP or UDP client and the other as a TCP/UDP server. When setting up the server the remote IP address section must contain the address of the client. This will allow the client's IP address to pass the IP address-filtering feature of the server. Conversely, the Remote IP address of the client must contain the server's IP address. Both communication port numbers must be the same.

### Heart Beat

The **Heart Beat** protocol connection provides a reliable communications connection in **Virtual COM Port Mode** or with **Paired Connection Mode**. This feature restores the connection if communications are temporarily lost at either end due to loss of power or Ethernet connection.

Without this feature a device that loses a connection and stops communicating would not be able to reconnect without human intervention. A TCP data connection can be lost when there is a power failure or temporary loss of an Ethernet connection on either the client or server. If a loss occurs the Heart Beat feature will try to reconnect the TCP data connection every five seconds until communications is established again. The Heart Beat feature is available for use in **Virtual COM Port Mode** and **Paired Connection Mode**. This is not available when using a UDP application.

## Serial Server Quick Start Guide

For descriptive purposes this Quick Start Guide considers a typical configuration consisting of a **PC** connected via an Ethernet LAN to an **ESR902 Serial Server** connected to the RS-232 port of a **serial device**.

### Hardware Setup

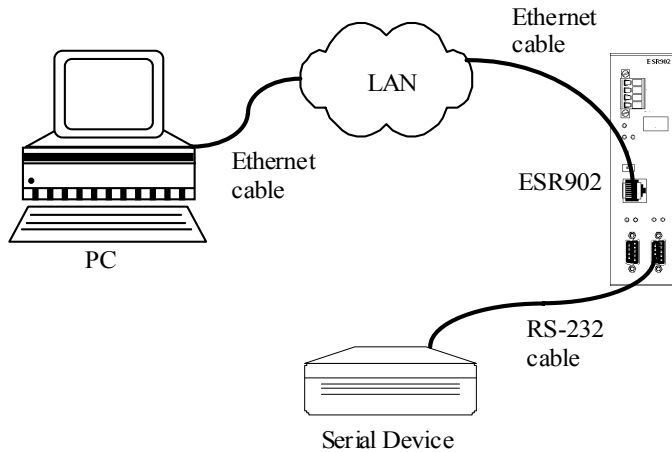

Figure 2. Typical Hardware Setup

**Step 1:** Connect the **Serial Server** to the network using a standard network cable.

**Step 2:** Connect the **Serial Server** to the RS-232 port on the **serial device**.

#### Note:

*If the serial device is configured as a DCE use a straight-through serial cable. If the serial device is configured as a DTE use a crossover (null modem) cable.*

**Step 3:** Set the **Run/Console** DIP switch to the **Run** position.

**Step 4:** Apply power to the **Serial Server**.

### Software Installation

Using the CD included with the **Serial Server**, install the **VLINX Manager** software on the configuring computer.

## Serial Server Configuration

**Step 1:** Open the **ESP Manager** software. It will automatically search for any reachable (ESP or ESR) Serial Servers. A list of all Serial Servers connected to the LAN will appear in the **Serial Server List** window.

**Step 2:** Double click the desired Serial Server port on the list to bring up the **Server Properties** configuration screen.

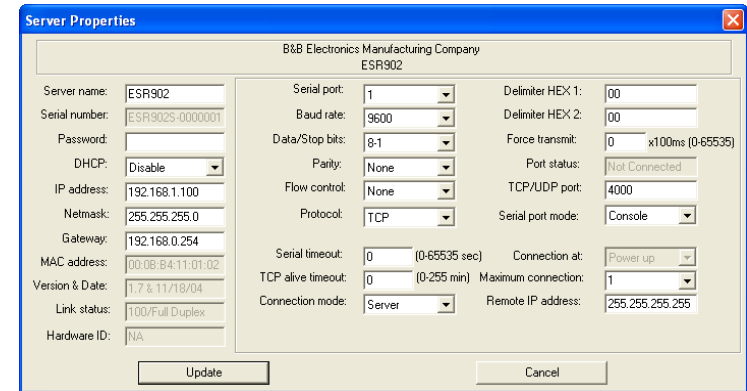

Figure 3. The Server Properties Window

**Step 3:** Change the **Server Properties** as required.

- Enable **DHCP** to allow the Serial Server to generate its own IP address

#### OR

- Obtain appropriate static **IP**, **Netmask** and **Gateway** addresses from your Network Administrator (**recommended**)
- Set the **Serial Port Mode** property to RS-232 to match the serial device connected to the **Serial Server**.
- Set **Baud Rate**, **Data/Parity/Stop**, and **Flow Control** to match the configuration of the serial device connected to the **Serial Server** port

**Step 4:** When the parameters have been set, click **Update**. Following the prompts in the dialogue boxes, **Restart** the Serial Server and **Search all reachable servers** again.

**Step 5:** Re-enter **Server Properties** to verify the changes have taken effect, or to view/change the configuration of other ports. Each port must be configured separately.

### **Install Virtual COM Ports on PC**

**Step 1:** From the **Windows Start** menu, run the **Install Virtual COM Ports** utility included with the VLINX software,

**Step 2:** Search for all servers on the network

**Step 3:** Select a port and map it to an unused COM port (e.g. Port 15). Configure it for TCP protocol and the appropriate IP address (determined in the last section).

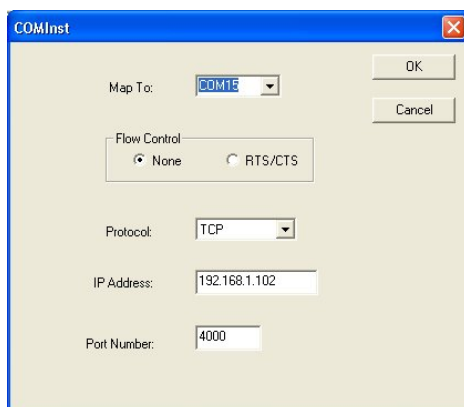

Figure 4. Configuring the Virtual COM Port

### **Check Communications**

**Step 1:** From the **Windows Start** menu, run **HyperTerminal**

**Step 2:** Configure **HyperTerminal** to connect using the COM port configured in the last section (e.g. Port 15).

**Step 3:** Set **Baud Rate**, **Data/Parity/Stop**, and **Flow Control** to match the configuration of the serial device connected to the **Serial Server** serial port.

**Step 4:** Communications with the serial device should now be operational.

## Chapter 2: MAKING THE HARDWARE CONNECTIONS

### Package Checklist

ESR90x Serial Servers are shipped with the following items included:

- ✓ Serial Server Module
- ✓ This Operation Manual
- ✓ CD-ROM disc with manual, VLINX ESP Manager and Virtual COM Driver software for Windows 98/ME/2000/XP/NT 4.0

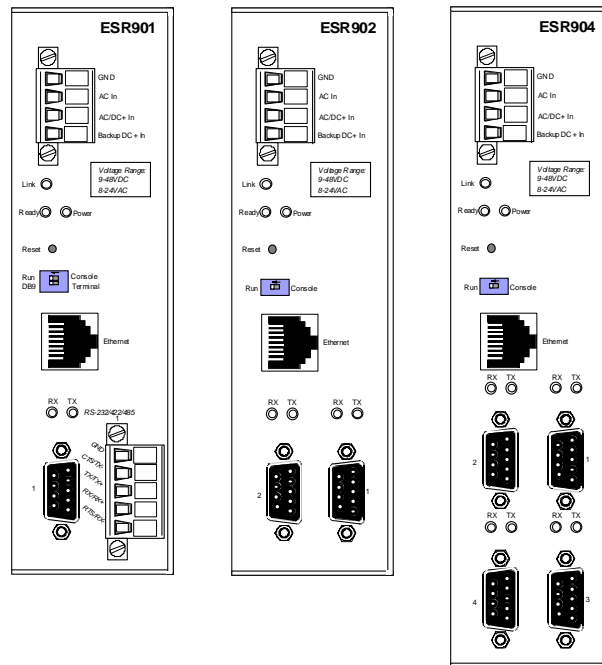

Figure 5. Front View of the ESR901, ESR902 and ESR904 Serial Servers

## ESR90x Indicators, Switches and Connectors

### Indicators

- One bi-color Link LED (Yellow = 10BaseT, Green = 100Base T)
- One green Ready LED (flashing = system ready)
- One red Power LED
- One red RX LED and one green TX LED for each serial port

### Switches

#### Reset

A recessed reset switch that allows the unit to be reset. Insert a small plastic tool, press lightly and hold for three seconds. The Link and Ready lights will go out and then come back on.

#### Run/Console Switch

A recessed single DIP (dual inline package) switch that allows the Serial Server to be switched between Run Mode and Console Mode. When switched to the Console position the Serial Server enters Console Mode. This allows you to configure the Serial Server from a PC running a terminal program such as HyperTerminal without connecting the server to the network. To communicate with the connected serial device the switch must be returned to “Run” position.

#### DB-9/Terminal Switch (ESR901 only)

Allows connection to the serial port (RS-232, 422 or 485) via the DB-9M connector or the five-terminal removable terminal block.

### Connectors

#### Ethernet Connector

One standard RJ-45 receptacle that allows the Serial Server to be connected to an Ethernet hub, switch, or wall plate using a standard straight-through RJ-45 (male) Ethernet cable. To connect directly to an RJ-45 Ethernet port on a PC or laptop a crossover Ethernet cable must be used.

**Serial Port(s)**

- **ESR901:** One serial port with two connector options: one (DB-9M) or one five-terminal removable terminal block (DIP switch selectable)
- **ESR902:** Two serial port connectors (DB-9M)
- **ESR904:** Four serial port connectors (DB-9M)

**Note:**

Refer to Appendices A, B and C for connection pin-outs.

**Power Connector**

The power connector is a removable terminal block with four terminals. From top to bottom the terminals are:

Terminal	Connect to	Description
GND	Negative side of DC power supply (if DC power used) Also connect negative side of Backup DC power supply (if used)	Internally, the chassis ground of the Serial Server is connected to this terminal.
AC In	One side of AC power supply (if AC power used)	Either AC or DC power can be used to power ESR Serial Servers. Power supply can voltages range from 9 V to 48 VDC or 8 V to 24 VAC.
AC/DC + In	The other side of AC power supply (if AC power used) OR Positive side of DC power supply (if DC power used)	
Backup DC+ In	Positive side of Backup DC power supply	Backup power must be DC voltage and can be any voltage between 9 VDC and 48 VDC.

**Serial Server/Port Operational Modes**

Using the **ESP Manager**, **Web Server** or **Telnet** the Serial Server can be put into Console Mode, Default Mode or Upgrade Mode. The serial ports can be configured for RS-232, RS-422, RS-485H (half duplex) or RS-485F (full duplex) operation. The server also can be put into **Console Mode** by placing the **Run/Console** switch in the **Console** position.

**Default Mode**

When **Default Mode** is selected and the server properties are **Updated (Saved)** all the configuration settings return to their default values.

**Note:**

Refer to Chapter 5 for details on Serial Server Configuration settings. See Chapter 12 for Serial Server default parameters.

**Console Mode**

In **Console Mode** the **Configuration Menu** can be accessed from a PC by connecting its RS-232 serial port to the ESR901 serial port or ESR902/904 Serial Port 1. Since the computer is a DTE device, and the serial ports are configured as DTEs (with DB-9M connectors), a null modem crossover cable must be used.

In **Console Mode** the default serial port settings are: **9600 baud**, **8 data bits**, **No parity**, and **1 stop bit**. From Windows, HyperTerminal with VT100 terminal emulation can be used for **Console Mode** configuration.

**Note:**

Refer to Chapter 9 for details on Console Mode

**Upgrade Mode**

In **Upgrade Mode** firmware can be uploaded from a PC via its serial port to the ESR901 serial port or ESR902/904 Serial Port 1. Upgrading also can be accomplished via the network connection, using the ESP Manager software and a virtual COM port.

**Note:**

Refer to Chapter 8 for details on Upgrade Mode

**RS-232 Mode**

In **RS-232 Mode** the currently selected serial port is configured as an RS-232 interface supporting eight RS-232 signal lines plus Signal Ground and is configured as a DTE, like a computer. Signals are single ended and referenced to Ground. To use handshaking, Flow Control must be set to RTS/CTS during configuration.

**RS-422 Mode**

In **RS-422 Mode** the currently selected serial port is configured as an RS-422 interface supporting four RS-422 signal channels with full duplex operation for **Receive**, **Transmit**, **RTS** (Request To Send) and **CTS** (Clear To Send). The data lines are differential pairs (A & B) in which the B line is positive relative to the A line in the idle (mark) state. Ground provides a common mode reference. To use handshaking, Flow Control must be set to RTS/CTS during configuration.

**RS-485H Mode**

In **RS-485H Mode** the currently selected port is configured as a two-wire RS-485 interface supporting DataB(+) and DataA(-) signal channels using half-duplex operation. The data lines are differential with the Data B line positive relative to Data A in the idle (mark) state. Ground provides a common mode reference.

**RS-485F Mode**

In **RS-485F Mode** the currently selected port is configured as a four-wire RS-485 interface supporting transmit lines TXDB(+) and TXDA(-) and receive lines RXDB(+) and RXDA(-) for full duplex operation. The lines are differential with the B line positive relative to A in the idle (mark) state. Ground provides a common mode reference.

**RS-485 Receiver Biasing**

**RS-485 Receiver Biasing** can be implemented from the Serial Server if the network does not supply it. Remove the four screws from the cover of the Serial Server, slide the cover off and re-position the bias jumpers as indicated in the diagrams and tables below. Note that ESR Serial Servers provide separate jumpers for RS-485 half duplex and RS-422/485 full duplex operation. Also, the ESR901 provides separate jumpers for the terminal block and DB-9 connectors. Biasing jumpers are also provided for CTS inputs.

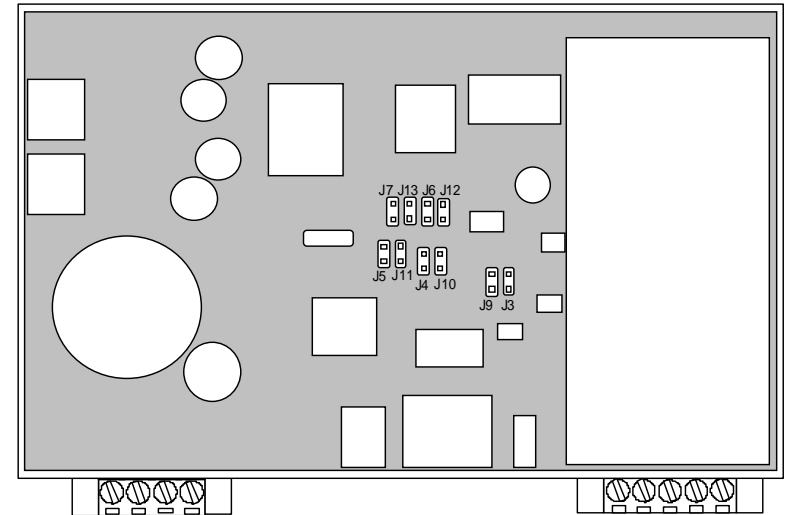

Figure 6. ESR901 Bias Jumper Locations

Connector	Interface Type	Jumper Number	Pull up/pull down
Terminal block	485 half duplex	J12	pull up
		J6	pull down
	422/485 full duplex	J7	pull up
		J13	pull down
DB-9	485 half duplex	J3	pull up
		J9	pull down
	422/485 full duplex	J5	pull up
		J11	pull down
	CTS	J4	pull up
		J10	pull down

Figure 7. ESR901 Bias Jumpers

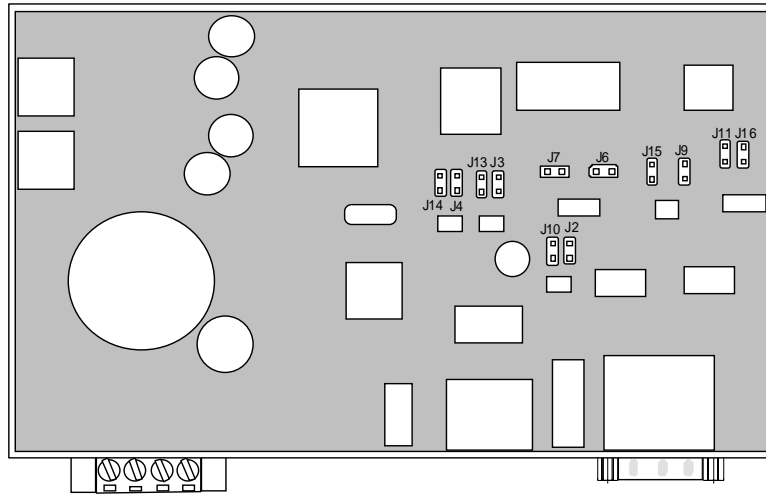

Figure 8. ESR902 Bias Jumper Locations

Port	Interface Type	Jumper Number	Pull up/pull down
1	485 half duplex	J2	pull up
		J10	pull down
	422/485 full duplex	J4	pull up
		J14	pull down
	CTS	J7	pull up
J6		pull down	
2	485 half duplex	J9	pull up
		J15	pull down
	422/485 full duplex	J3	pull up
		J13	pull down
	CTS	J11	pull up
J16		pull down	

Figure 9. ESR902 Bias Jumpers

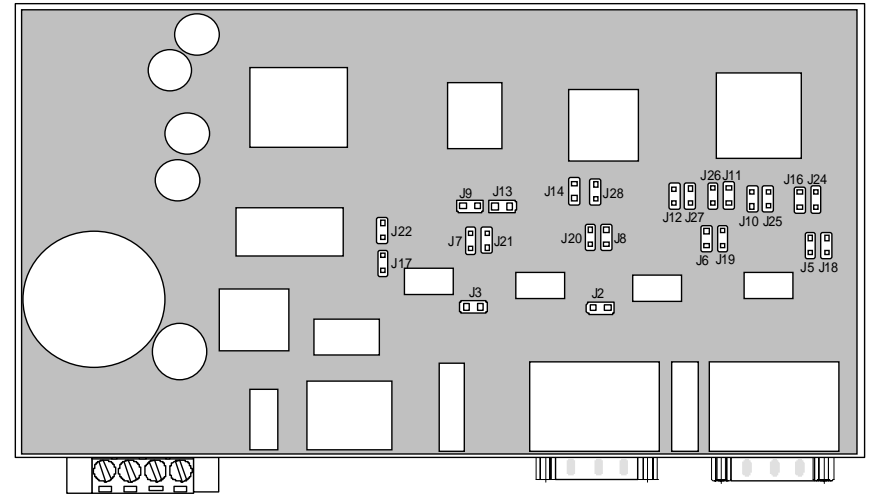

Figure 10. ESR904 Bias Jumper Locations

Port	Interface Type	Jumper Number	Pull up/pull down
1	485 half duplex	J22	pull up
		J17	pull down
	422/485 full duplex	J7	pull up
		J21	pull down
	CTS	J13	pull up
		J9	pull down
2	485 half duplex	J3	pull up
		J2	pull down
	422/485 full duplex	J8	pull up
		J20	pull down
	CTS	J14	pull up
		J28	pull down
3	485 half duplex	J12	pull up
		J27	pull down
	422/485 full duplex	J6	pull up
		J19	pull down
	CTS	J11	pull up
		J26	pull down
4	485 half duplex	J16	pull up
		J24	pull down
	422/485 full duplex	J5	pull up
		J18	pull down
	CTS	J10	pull up
		J25	pull down

Figure 11. ESR904 Bias Jumpers

**Note:**

(For more information on RS-485 Receiver Biasing, see B&B Electronics RS-422/485 Application Note available at [www.bb-elec.com](http://www.bb-elec.com))

## Chapter 3: INSTALLING THE VLINX SOFTWARE

The Windows-based **ESP Manager** and **Virtual COM Port** software makes configuration fast and easy. If using Windows, installing the ESP Manager software and setting up virtual COM ports to configure the Serial Server is recommended.

### Software Installation

The **VLINX software** includes:

- **ESP Manager**
- **Install Virtual COM Ports**
- **Uninstall Virtual COM Ports**

### Automatic Installation

**Step 1a:** Inserting the VLINX CD in the CD-ROM should automatically launch the Install Shield Wizard.

### Manual Installation

**Step 1b:** To manually start the software installation, from the **Windows Desktop**, click **Start** button. At the **Run** command line type **D:start.exe** then click **OK**. (**D:** is the drive letter for the CD ROM.)

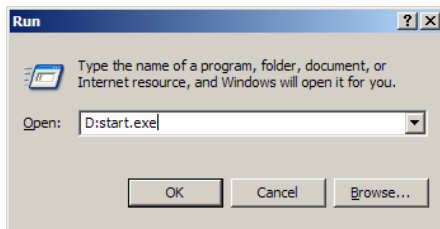

Figure 12. The Run Dialogue Box

The **Install Shield Wizard** window will be displayed.

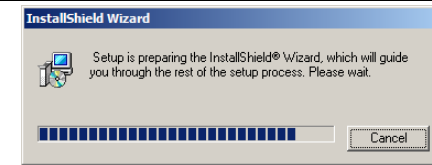

Figure 13. The Install Shield Wizard Window

**Step 2:** When the **VLINX ESP Setup** window appears, click **Next**.

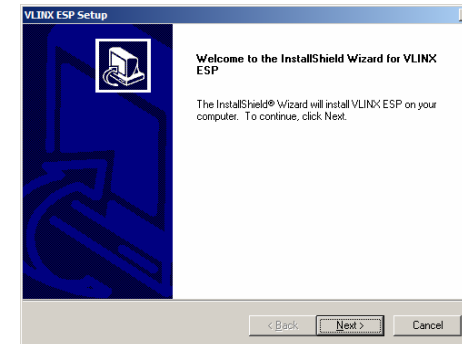

Figure 14. VLINX ESP Setup Window

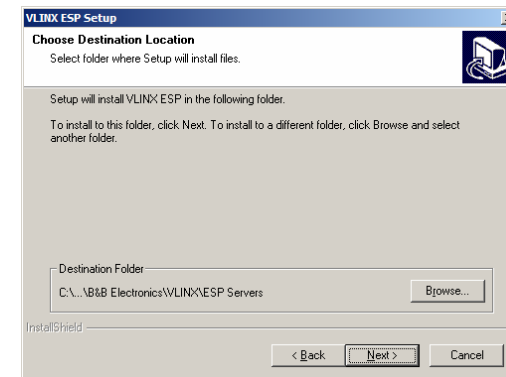

Figure 15. The Choose Destination Window

**Step 3:** When **Choose Destination Location** appears, click **Next**.

The installation progress will be shown until complete.

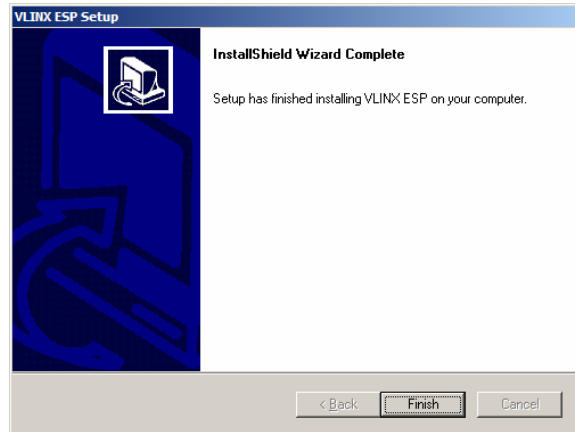

Figure 16. The Install Shield Wizard Complete Window

**Step 4:** Click **Finish** when the **Install Shield Wizard Complete** dialogue appears. When finished, dialogue box will close.

### Updating an Existing Installation

If an older version of the **ESP Manager** software is already installed, the **Modify, repair or remove the program** window will appear when the installation process is initiated:

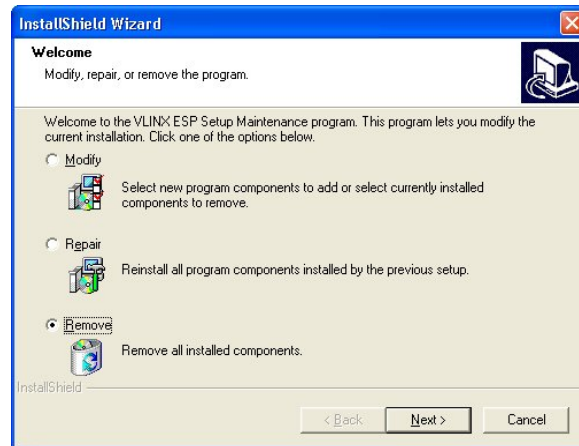

Figure 17. The InstallShield Wizard Modify, Repair or Remove Screen

The recommended procedure is to **Remove all installed components** first. Once the software has been removed, **Install** the new software.

### Opening the ESP Manager

**Step 5:** If the Serial Server is not already connected to the network or to the Ethernet port on the computer, connect it. Set the Run/Console switch to the Run position. Apply power.

The **Power** indicator should light red, the **Link** light should indicate which type of Ethernet connection has been made and the **Ready** LED will flash indicating configuration can begin.

**Step 6:** Start the **ESP Manager** software. In Windows Desktop, click:

**Start → Programs → B&B Electronics → VLINX → ESR Servers → VLINX ESP Manager.**

As soon as the **ESP Manager** opens it will initiate **Searching Server** and after a few seconds the **Serial Server List** will display all (ESP90x and ESR90x) Serial Servers on the network.

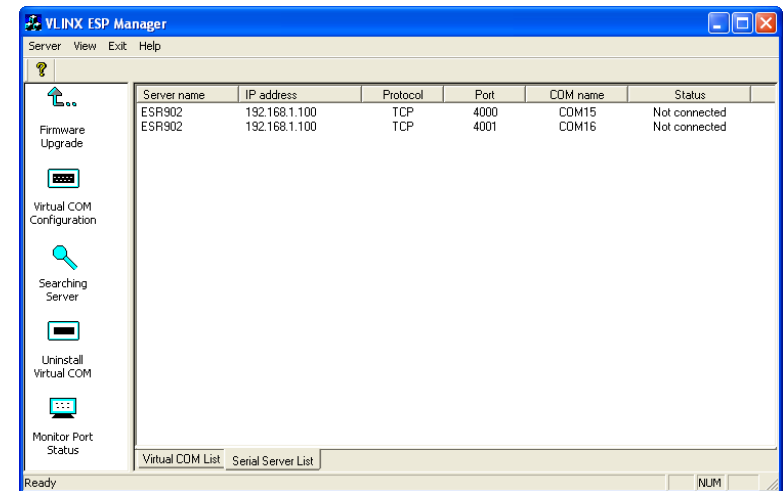

Figure 18. ESP Manager Displaying all ESR90x Serial Servers

## Chapter 4: USING ESP MANAGER

The **ESP Manager** software allows:

- Searching for servers connected to the network
- Displaying and changing the configuration of those servers
- Installing virtual COM ports on a computer
- Displaying and configuring virtual COM ports
- Uninstalling virtual COM ports on a computer
- Upgrading the Serial Server firmware
- Monitoring Port Status
- Saving and Loading Configuration Files

### Hardware Setup

**Step 1:** Connect the Serial Server to the LAN or to a computer Ethernet port. Set the Run/Console DIP switch on the Serial Server to the Run position

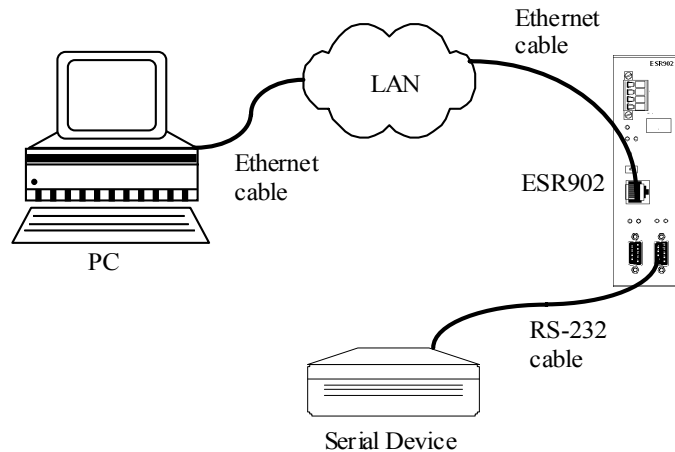

Figure 19. Ethernet Connection via a LAN

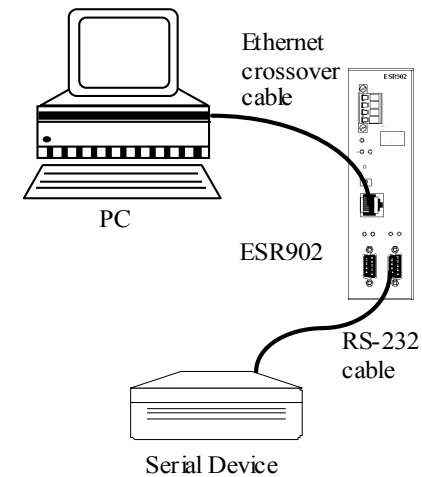

Figure 20. Direct Ethernet Connection using a Crossover Cable

#### Note:

Use an Ethernet Crossover Cable if connecting directly to a computer LAN card.

**Step 2:** Apply power. The red Power indicator will light, the Link indicator lights when an Ethernet connection is made, and the Ready indicator will flash.

### Software Setup

**Step 3.** To run the **ESP Manager**, from the **Windows Desktop** click:

**Start** → **Programs** → **B&B Electronics** → **VLINX** → **ESR Servers** → **VLINX ESP Manager**

As soon as the **ESP Manager** opens it will initiate **Searching Server** and after a few seconds the **Serial Server List** will display all (ESP90x and ESR90x) Serial Servers on the network.

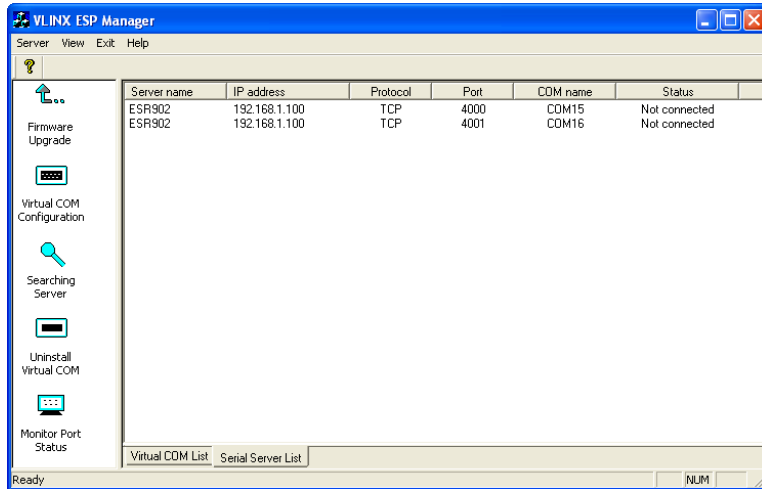

Figure 21. The VLINX ESP Manager Window

## Software Overview

The VLINX ESP Manager window provides the following information:

- **Menus** (Server, View, Exit, Help)
- **Server Icons** (Firmware Upgrade, Virtual COM Configuration, Searching Server, Uninstall Virtual COM, Monitor Port Status)
- **Serial Server / Virtual COM Lists**
- **Software Status** (Ready, Updating, Searching, etc)

## Menus

### Server

- **Firmware Upgrade** - Used when downloading new firmware to the Serial Server.

#### Note:

See Chapter 8 for more information on upgrading firmware.

- **Virtual COM Configuration** - Selects the **Virtual COM List**. Double clicking on any COM port in the **Virtual COM List** brings up a window that allows changing the virtual COM settings such as **Flow Control**, **Protocol**, **IP address**, and **Port Number**. Virtual COM settings must match Serial Server port settings.

- **Searching Server** - Searches for Serial Servers on the network and brings back configuration information that will be displayed in the **Server Properties** window.
- **Uninstall Virtual COM** - Allows virtual COM ports to be uninstalled from the **ESP Manager** window.
- **Monitor Port Status** - Brings up a screen that displays the following information associated with the selected serial port:
  - **Serial TX:** Displays the number of bytes of data sent to the **serial device** since the IP connection was established.
  - **Serial RX:** Displays the number of bytes of data received from the connected **serial device** since the IP connection was established.
  - **DTR/RTS:** The **DTR/RTS Port Status** indicator displays the current logic state of the DTR and RTS hardware handshake (output) lines for the selected Serial Server port (1 = asserted, 0 = not asserted).
  - **DCD/DSR/CTS:** The **DCD/DSR/CTS Port Status** indicator displays the current logic state being received on the DCD, DSR and CTS hardware handshake (input) lines for the selected Serial Server port (1 = asserted, 0 = not asserted)
  - **Status:** Indicates whether the client software has made a connection with the Serial Server.
  - **IP Address:** Displays the IP address of the connected client when there is a client connection
- **Save Configuration File** - Allows the user to save the current configuration information to a file with a .vcom extension.
- **Load Configuration File** - Allows the user to load a configuration file.

### View

Provides three viewing options for the ESP Manager screen:

- **Toolbar** – allows the toolbar (directly under the menu bar) to be viewable or hidden
- **Status Bar** – allows the Status Bar (at the bottom of the screen to be viewable or hidden
- **Split** – allows the position of the split between the Icons pane and the Virtual COM List / Serial Server List panes to be dragged horizontally using the mouse

*Exit*

- Allows you to **Exit** the **ESP Manager** program

*Help*

- Accesses the **About vcomui** dialogue box, which indicates the software version number

**Server Icons Pane**

**Firmware Upgrade**, **Virtual COM Configuration**, **Searching Server**, **Uninstall Virtual COM** and **Monitor Port Status** can also be selected using icons located in the left window.

**Serial Server / Virtual COM Lists**

To make management of lists of serial server easier, lists can be sorted by clicking on any tab heading. Scrolling bars facilitate scrolling through long lists.

*Serial Server List*

- **Server Name** - Displays the name of the Serial Server. The name is listed once for each port.
- **IP Address** - Displays the IP Address for the Serial Server. All ports in a **Serial Server** have the same the same IP address.
- **Protocol** - Displays the currently selected TCP or UDP mode for the **Serial Server**.
- **Port** - Displays the port number for each Serial Server port.
- **COM Name** - Displays the name of the computer COM port mapped to each Serial Server port. If no computer port has been mapped it displays **Not mapped**.
- **Status** - The Status indicates the mapped virtual COM port condition.
  - **Not Connected** is shown when a program does not have the port Open.
  - **Connected** is shown when that mapped port is Open for use.

*Virtual COM List*

- **COM Name** - Displays the number of the COM port mapped to each Serial Server port.
- **IP Address** - Displays the IP Address for the Serial Server. All ports in a Serial Server have the same IP address.

- **Protocol** - Displays the currently selected TCP or UDP mode for the Serial Server.
- **Port** - Displays the port number for each Serial Server port.
- **Flow Control** - Indicates what type of flow control is configured for each port.
- **Status** - Indicates whether each port is currently **In Use** or **Not Used**.

**Status Bar**

Displays the current status of the software in the bottom, left corner of the screen

- Ready
- Updating
- Searching reachable servers...

**Search for Servers**

Upon opening the **ESP Manager** software it will automatically execute Searching Server and search for all reachable ESR90x serial servers.

**Step 4:** To manually initiate a search for servers, click **Searching Servers** (under the **Servers** menu or the icon on the left side of the screen). The **Search Setup** box will appear.

It provides two options for searching for servers on the network:

- Specify the IP Address of the Serial Server
- Search all reachable servers

**Step 5:** Enter the **IP Address** assigned to the desired Serial Server or click **Search all reachable servers**, then **OK**. **IP Address** is used to find Serial Server units that are not on the same subnet. (Routers on the network will block the standard broadcast used to find servers if **Search all reachable servers** is selected.) The user must set an IP address that conforms to the LAN addressing scheme.

The Searching window is shown until all active Serial Servers on the LAN are listed in the **Serial Server List** window.

## Configure Server Properties

The **Server Properties** window displays the current configuration properties for the currently selected server.

**Step 6:** To open the **Server Properties** window, highlight the Serial Server in the **Serial Server List** window, double-click to open.

The **Server Properties** window is used to configure and store the Server configuration settings. Details for setting Properties are described in the next chapter.

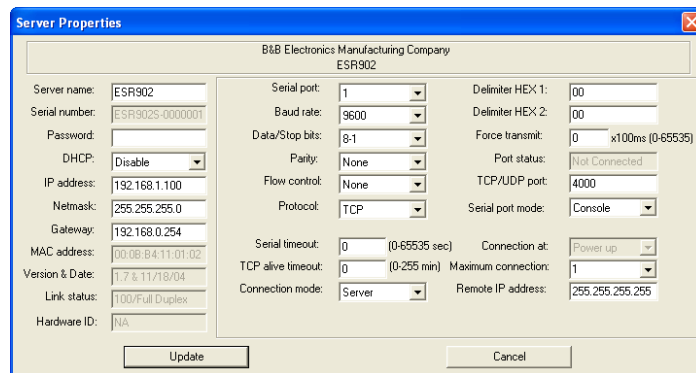

Figure 22. The Server Properties Window

### Note:

ESP Manager Navigation:

- Use the mouse to select the property and parameters or
- Tab to move to the next property
- Tab+Shift to move back to previous property
- Arrows to move between properties or change values or contents of the current property
- Enter to select update or cancel

**Step 7:** After configuring as needed, click **Update** to store the configuration in the server.

**Step 8:** Click **Yes** to restart. A dialogue box will appear indicating the server is restarting, then a dialogue box will ask whether you want to search for all reachable servers again.

**Step 9:** Click **Yes**.

After the port has been updated you may want to re-enter **Server Properties** to verify the changes have taken effect, or to view/change the configuration of other ports. Each port must be configured separately.

## Chapter 5: CONFIGURING THE SERIAL SERVER PROPERTIES

The **VLINX Serial Server** can be configured using any of four different user interfaces: the **ESP Manager** software, **Console Mode**, **Telnet** or the **Web Server**. The **Server Properties** described in this chapter can be changed from any of these user interfaces.

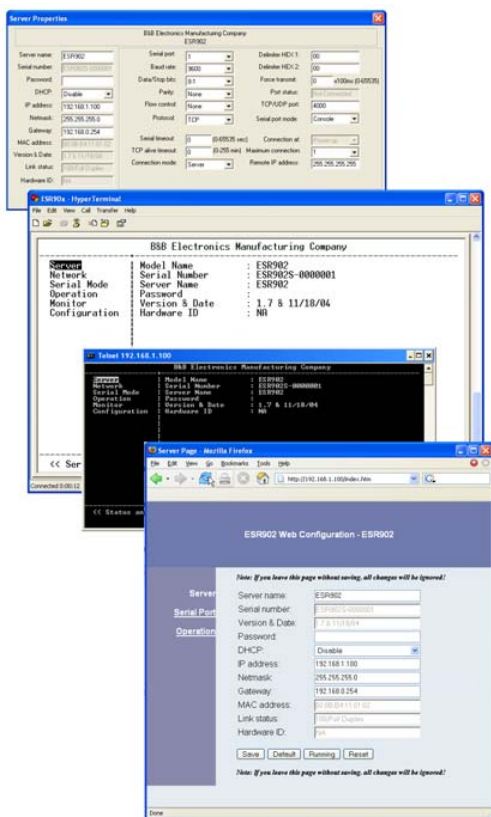

Figure 23. The Four Methods of Configuring Server Properties

## Description of the Server Properties

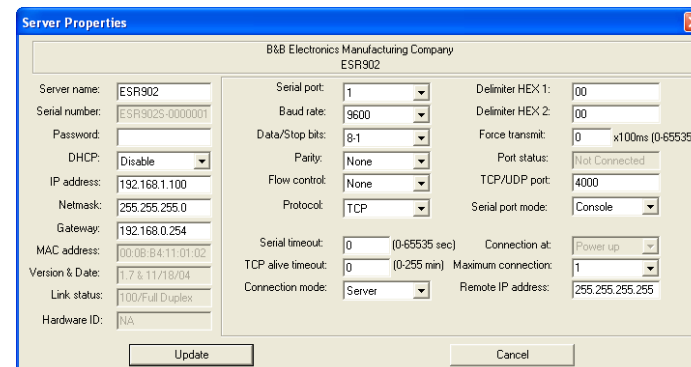

Figure 24. ESP Manager Server Properties Window

### Server Name

This field displays the name that has been assigned to the Serial Server. A new **Server Name** of up to 16 characters can be entered. If more than one Serial Server is connected on the LAN it is recommended that a new name be assigned to each. When the **ESP Manager** finds a Serial Server on the LAN it displays the server name and IP Address allowing the user to distinguish between Serial Servers.

### Serial Number

Each Serial Server has a unique serial number. It is fixed and cannot be changed.

### Password

Entering a password activates a security feature on the Serial Server. Once a password is entered it will be required to access the menu and make changes.

### DHCP

DHCP servers are a part of numerous LAN management systems. The DHCP field provides two choices: **Disable** and **Enable**. Disable is the normal, or default, setting. When enabled, the Serial Server will send a DHCP request to the DHCP server, which will assign a dynamic IP address, net mask, and gateway to the Serial Server. If a DHCP server is not available on the network the Serial Server will time out after 10 seconds and the default

values will remain. When DHCP is enabled, the IP Address, Netmask and Gateway fields become inaccessible and cannot be changed by the user.

**Note:**

A dynamic address assigned by the DHCP server may change if the server loses the Ethernet connection or power is removed. The host (client) communication software requests a connection to the specific IP address of the serial server. If the DHCP reassigns a different IP address the software will not be able to communicate with the hardware. Therefore, using a static IP address is recommended.

**IP Address**

Software or hardware attempting to access the Serial Server via the network must know the **IP Address** of the server. A static IP address is retained and remains the same each time the server is powered up or starts/restarts. The default IP address of the Serial Server is printed on a label on its bottom cover. Entering an appropriate address in the IP Address field and updating the server will change the server's IP address. The network administrator can assign/establish the static address or group of addresses to be used.

The IP Address of the Serial Server can be confirmed using the DOS Ping command.

**Note:**

To use **Ping** to check for communications:

- Access a DOS window (in XP click **Start**, then **Run**)
- At run prompt enter: **CMD**
- In the DOS window enter: **Ping xxx.xxx.xxx.xxx** (IP address for the server to be confirmed)
- The command will return the Ping results indicating 4 replies

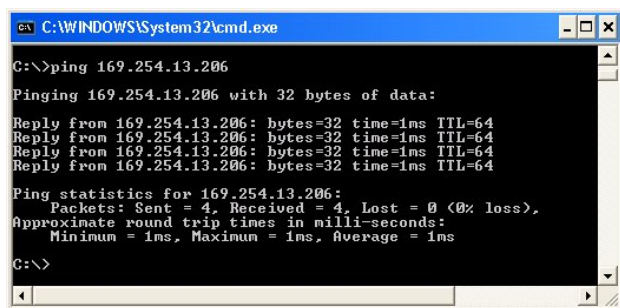

```

C:\WINDOWS\System32\cmd.exe
C:\>ping 169.254.13.206
Pinging 169.254.13.206 with 32 bytes of data:
Reply from 169.254.13.206: bytes=32 time=1ms TTL=64
Reply from 169.254.13.206: bytes=32 time=1ms TTL=64
Reply from 169.254.13.206: bytes=32 time=1ms TTL=64
Reply from 169.254.13.206: bytes=32 time=1ms TTL=64

Ping statistics for 169.254.13.206:
    Packets: Sent = 4, Received = 4, Lost = 0 (0% loss),
    Approximate round trip times in milli-seconds:
        Minimum = 1ms, Maximum = 1ms, Average = 1ms
C:\>

```

Figure 25. Pinging using the DOS command window

**Netmask**

The default LAN netmask is configured for a Class C address. The user may change this. Default is 255.255.255.0

**Gateway**

The Gateway IP address allows users to access the Serial Server from outside the LAN.

**MAC Address**

The MAC address is fixed and cannot be changed. It is assigned in the factory. Every Ethernet device manufactured has its own unique MAC address.

**Version & Date**

The currently loaded version of the firmware, and when it was released, is shown here.

**Link Status**

Link status automatically displays the type of Ethernet connection. It will either display 10BaseT or 100BaseTX in full duplex or half duplex. This will depend on the LAN, switches, hubs used in the LAN topology.

**Server Serial Port**

This field indicates the number of the port for which Serial Server properties are currently being displayed. Changing the number in this field will cause all the other fields to display the properties for the specified port. Note, however, that before changing ports, any changes to properties must be **Updated** (Saved) or the **n** will not retain them.

**Baud Rate**

The serial port baud rate on the Serial Server must match the serial baud rate of the connected device unless using Virtual COM Mode. In Virtual COM Mode the software program will establish serial settings.

**Data/Parity/Stop**

Set this to match the data format used by the serial device connected when Virtual COM Mode is not being used.

## Flow Control

The Flow Control setting must match the requirements of the serial device connected.

### Note:

Select None when setting the port as RS-485 or 4-wire RS-422.

## TCP/UDP Protocol

Select **TCP** (Transmission Control Protocol) or **UDP** (User Datagram Protocol) protocol. If the application does not require a UDP connection, select TCP. TCP guarantees reliable communication with error checking whereas UDP provides faster transmission.

### UDP Mode

When UDP mode is chosen the **Serial timeout**, **TCP alive timeout**, **Connection mode**, **Connection at**, **Max connection** and **Remote IP address** fields are replaced with the following four fields: **Destination IP address range**, **Port number** and **Source IP address range**. In this mode the server can be configured to broadcast data to and receive data from multiple IP addresses. Four IP address range fields are provided.

The screenshot shows the 'Server Properties' dialog box for a device named 'ESR902'. The 'Protocol' is set to 'UDP'. Under the 'Destination IP address range' and 'Source IP address range' sections, there are four rows of input fields for IP addresses and port numbers. The 'Port' column is set to '4000' for all rows. The 'Update' and 'Cancel' buttons are at the bottom.

Figure 26. The Server UDP Configuration Screen

## Serial Timeout

Default for the **Timeout** property is 0, or no timeout. Setting **Timeout** to any value between 1 and 65535 seconds activates it. If **Timeout** is set to 5 seconds and the Serial Server is configured as a **Server**, the **Client** makes a connection and communications starts. If communications are ideal for 5 seconds the **Serial Server** will reset and make itself available for another client connection.

## TCP Alive Timeout

The **Serial Server** monitors TCP activity. If TCP activity stops for the length of time specified in this field the connection will be closed. This field can be set to any value between 0 and 255 minutes. If zero, or no value, is entered into this field the server will not disconnect.

## Connection Mode

The Connection Mode field has three options: **Server**, **Client** and **Client (no heartbeat)**. When **Client** or **Client (no heartbeat)** is selected the **Connection at** field automatically becomes active (allowing the user to select **Power up** or **Data Arrival**).

- When using the **Virtual COM Port** feature, select **Server**.
- When using a **TCP** or **UDP Socket** program, select **Server**.
- When using **Paired Mode** communication between two serial servers set up one as a **Client** and the other as a **Server**.
- When connecting to a server that does not support **Heartbeat**, select **Client (no Heartbeat)**.

## Delimiter HEX 1 and Delimiter HEX 2

These fields allow the user to enter two ASCII characters (in hex format) that delimit the beginning and end of a message. When a message with both these delimiters is received at the serial port, the data contained in the serial buffer is placed in an Ethernet packet and sent out the Ethernet port. If only Delimiter 1 is set (Delimiter 2 is zero or blank), upon receiving Delimiter 1 the Serial Server will put all the data in the serial buffer in an Ethernet packet and send it out the Ethernet port. If serial data greater than 1 kilobyte is received it will automatically be placed in an Ethernet packet and sent out the Ethernet port.

## Force Transmit

This field allows the user to set a maximum time limit between transmissions of data. The value set in this field multiplied by 100 ms determines the Force Transmit time. When the elapsed time reaches the time configured in this field, the TCP/IP protocol will pack the data currently in the serial buffer into a packet and send it out the Ethernet port.

## Port Status

This field indicates whether a serial port is connected via the **Serial Server** to a virtual COM port of a device on the network.

## TCP/UDP Port

This sets the port number for connection. The default port number for the **ESR901** serial port is **4000**. The default port numbers for serials ports 1, 2, 3 and 4 are **4000, 4001, 4002** and **4003** respectively.

In all modes of operation, **Direct IP** or **Virtual COM**, the port number set in the **Server Properties** menu must match the **Virtual COM** or socket software port settings.

### Note:

*Example: The Virtual COM default setting is TCP/UDP Port 4000. If the port # property is changed to 4001, the virtual COM port will have to be changed to 4001. The hardware settings can be changed from the ESP Manager or Console Configuration Menu. The Virtual COM port setting also can be changed within the Device Manager of the computer on which it is installed.*

## Serial Port Mode

**Serial Port Mode** allows configuration of the serial server for the following modes of operation:

- **Console** – When this mode is selected and the server is updated, a PC running a communications program such as HyperTerminal can communicate with the Serial Server via the **Console Mode** serial port (the serial Port on ESR901 or Port 1 on ESR902/904), displaying the **Server Properties** screen and allowing configuration of the server and its ports.
- **Upgrade** – When this mode is selected and the server is updated, firmware can be uploaded into the Serial Server via the **Console Mode** serial port or a virtual COM port mapped to the number of the **Console Mode** serial port.

- **Default** – When this mode is selected and the server is updated, it will revert the server to its default configuration.
- **RS-232** – When this mode is selected and the server updated, the selected serial port will become an RS-232 serial port on the server.
- **RS-422** – When this mode is selected and the server updated, the selected serial port will become an RS-422 serial port on the server.
- **RS-485H** – When this mode is selected and the server updated, the selected serial port will become a two-wire, half-duplex RS-485 serial port on the server.
- **RS-485F** – When this mode is selected and the server updated, the selected serial port will become a four-wire, full-duplex RS-485 serial port on the server.

## Connection At

When the **Connection Mode** field is set to **Client** or **Client (no heartbeat)**, this field becomes active, allowing the Serial Server (acting as a client) to connect to the server either on **Power up** or on **Data Arrival** (first character arriving).

## Max Connection

This field allows the user to configure the Serial Server to have up to eight TCP connections.

## Remote IP Address

This is a security feature activated by entering the IP address of the desired client. The Serial Server will only communicate with the listed IP address and all other requests for connection will be filtered out. The Serial Server must be set up as a **TCP** or **UDP Server** to use this feature. The default setting is **255.255.255.255**.

If **Paired Mode** is not being used, do not change this setting until the application has been tested and is communicating properly. Then activate the address filtering feature.

### Note:

*Refer to Chapter 1 Paired Mode*

## Update/Save

Server properties must be updated separately for each serial port. Updating varies slightly depending on which of the four configuration user interfaces are used.

### Updating the Server Properties in ESP Manager

From the **Server Properties** screen, click the **Update** button to store the configuration settings for the currently selected port. The vcomui dialogue box will appear indicating you must restart the device before the new settings will take effect. Click **Yes**. After several seconds a dialogue box will ask whether you want to search for all reachable servers again. Click **Yes**.

After that port has been updated you may want to re-enter **Server Properties** to verify the changes have taken effect, or to view/change the configuration of other ports. Each port must be configured separately.

### Saving Configuration Data in Console Mode or Telnet

Saving (updating) server properties is done from the **Configuration** screen. Access the **Configuration** screen by tabbing through the list of screens on the left side of the window and highlighting **Configuration**.

There are four options shown on the right side of the **Configuration** screen: **Save**, **Default**, **Running** and **Reset**. Use **Tab**, **Backspace**, or **arrow** keys to move the cursor to the option position, and then press **Enter**.

- **Save** stores the configuration data to the Serial Server flash memory and resets it.
- **Default** restores the configuration data to factory default settings.
- **Running** restores the configuration data to the last values stored in the flash memory.
- **Reset** re-boots the Serial Server, making it available for a client connection.

### Web Server Interface

- The **Web Server** interface provides the same updating options as **Console Mode** and **Telnet**. These are located at the bottom of all three **Web Server** pages. If a field is changed, you must click **Save** before leaving that page or the changes will be ignored.

#### **Note:**

*If you leave any Web Server page without saving, any changes you have made will be ignored.*

## Chapter 6: INSTALLING VIRTUAL COM PORTS

The **Virtual COM Port** feature allows Windows platform software, using standard API calls, to be used in an Ethernet application.

The **Install Virtual COM Port** software adds a Serial Server (COM#) port to the computer. This shows up in the **Device Manager**. The COM number can be selected from a list of available numbers. For example, in a computer already having a COM1 and COM2, COM3 to COM 254 are available for the Serial Server. It is recommended that COM Port 5 or higher be selected. The virtual COM port looks like a standard COM port to most Windows based applications which allows the software to open a connection with the serial port located anywhere on the LAN/WAN. When using the virtual COM port the **Serial Server** is configured as a TCP or UDP Server.

### Virtual COM Port Installation

**Step 1:** From the **Windows Desktop**, click:

**Start → Programs → B&B Electronics → VLINX → ESP Servers → Install Virtual COM**

The **Search Setup** window will appear.

**Step 2:** Select the **Search all reachable servers** check box, then click **OK**.



Figure 27. The Search Setup Window

The program searches the LAN for all available Serial Servers. When complete, the **Found Server** window appears and displays a list of the servers that were found.

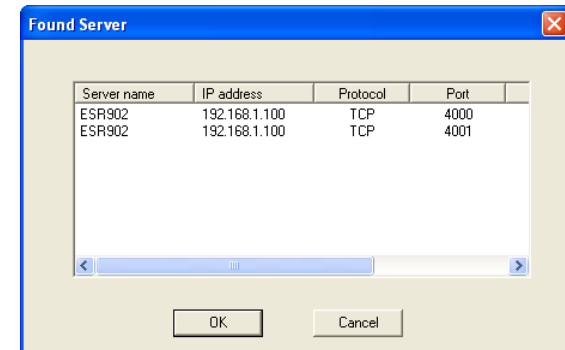

Figure 28. The Found Server Window

**Step 3:** Select the Serial Server at the IP Address to be mapped to a virtual COM port, then click **OK**.

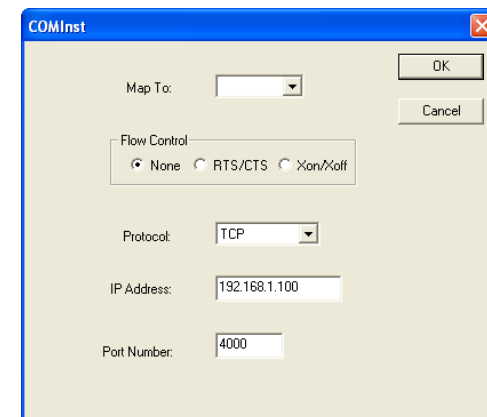

Figure 29. The COMInst Window

**Step 4:** In the **Map To:** field, **select** the number of the virtual COM port to be assigned. The default **Flow Control** setting is **None**. RTS/CTS can be selected if used by the application program and serial hardware. The Serial Server must be set to match. The Protocol TCP/UDP, IP Address, and Port Number will mirror the settings of the selected serial server. Click **OK**.

**Note:**

PCs may have hardware COM ports and devices such as Modems, IR ports or USB based COM ports that are not currently connected. Try selecting a COM number above COM4 if problems occur.

Windows XP provides a notice concerning Windows Logo testing for XP.



Figure 30. The Windows Logo Testing Window

This XP feature simply indicates that these drivers have not yet undergone the Microsoft testing procedures required to use the Windows XP Logo on the packaging. Driver compatibility is not affected.

**Step 5:** Click **Continue Anyway** to proceed with the installation.

**Step 6:** After setting all Serial Server serial ports as virtual COM ports, click **Cancel** on the **Found Server** form.

## Matching the Serial Server and Virtual COM Port Settings

The settings of the virtual COM ports in the **Device Manager** and the **Serial Server Configuration Menu** must match. If the settings do not match, the virtual COM ports will not work. If these settings are changed in the **Device Manager**, it will only affect the operation of the virtual COM port. It will not change the settings stored in the Serial Server. Use the **ESP Manager** to change the Serial Server settings.

**Step 1:** Use Device Manager to **View New Ports**

Confirm the virtual COM ports in the Device Manager.

**Step 2:** Double-click **Ports** to view the list of COM port numbers.

The installed Virtual COM port will be displayed as **VLINX ESP (COM #)**.

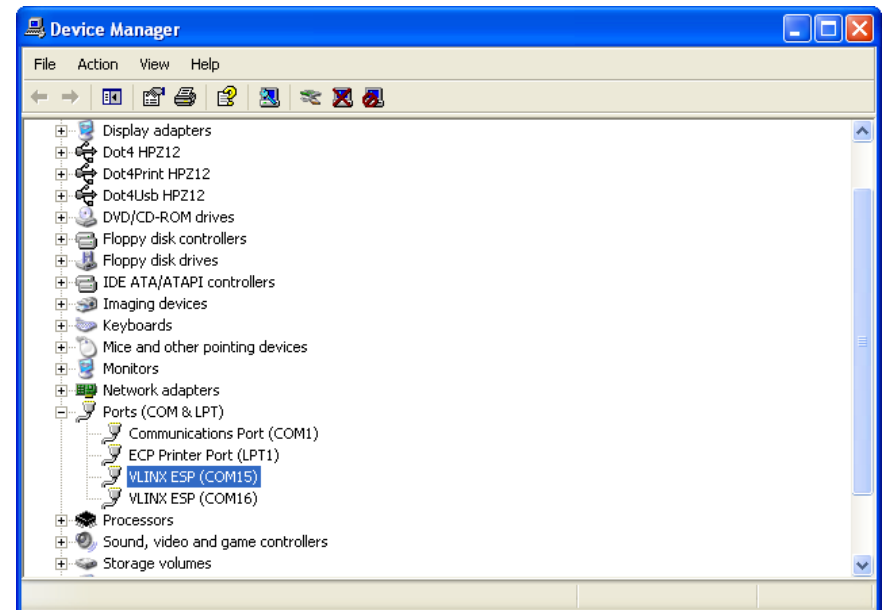

Figure 31. The Device Manager Window

**Step 3:** In the Device Manager select a **VLINX ESP COM#**. Double-click it to bring up the **Properties** window.

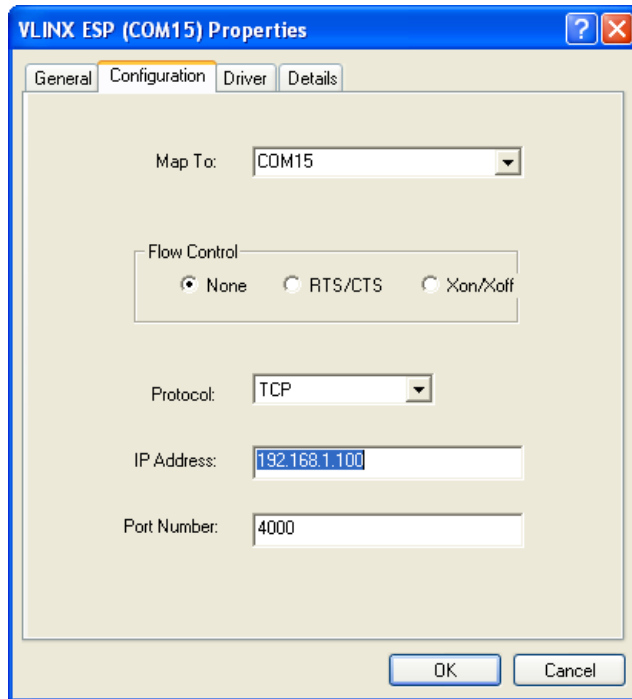

Figure 32. The VLINX ESR (COM3) Properties Window

**Step 4:** Click the **Configuration** or **Port Settings** tab. This screen allows the settings to be changed if necessary. Click **Cancel** to keep the existing settings.

**Step 5:** Click **OK** to change the settings. Use **Refresh** in the Device Manager if Windows does not auto refresh.

## Chapter 7: REMOVING VIRTUAL COM PORTS

The **ESP Manager** software **Uninstall Virtual COM Port** feature will remove a mapped COM port in the Device Manager of Windows 2000 and XP operating systems. It may also be removed in the Device Manager of Windows 98, ME, NT, 2000, and XP. Windows 98 users also will find a **Remove Virtual COM** feature in the Programs file.

### Removing the Virtual COM port with ESP Manager

**Step1:** From the Windows Desktop, click:

**Start → Programs → B&B Electronics → VLINX → ESR Servers → VLINX ESP Manager**

**Step 2:** In the **ESP Manager** window click the **Virtual COM List** tab. Highlight the mapped COM port number to be removed.

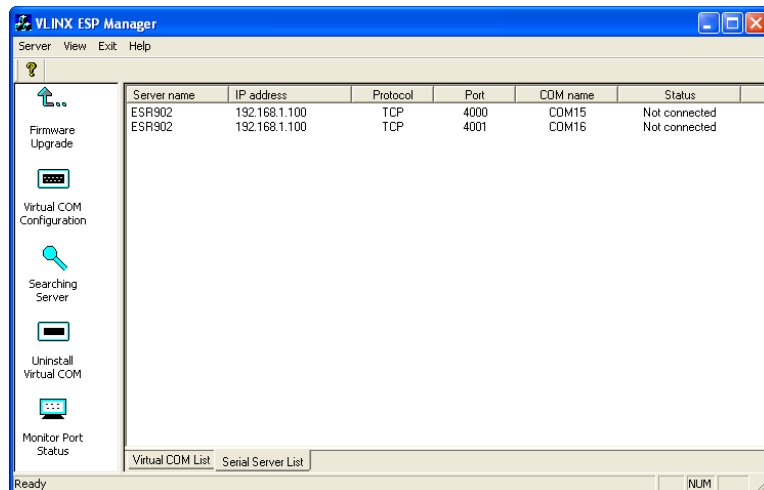

Figure 33. The ESP Manager Window

**Step 3:** Click the **Uninstall Virtual COM** icon. The Manager will ask for conformation. Click **OK** to complete the uninstall procedure.

### Removing the Virtual COM Port using Device Manager

**Note:**

The screen shots were taken from a Windows XP operating system

**Step 1:** From the Windows **Desktop** click:

**Start → Settings → Control Panel.**

**Step 2:** Click the **System** icon when the manager window opens.

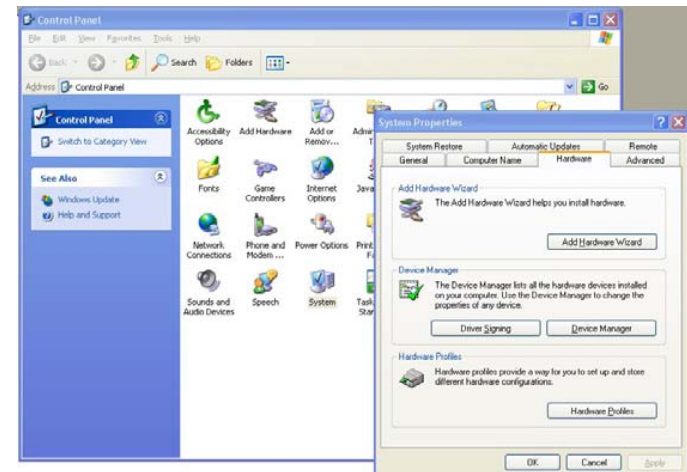

Figure 34. The Control Panel Window

**Step 3:** Click **Device Manager** in the **Systems Properties** window. In the Device Manager dialogue click the **+** next to **Ports (COM LPT)** to expand.

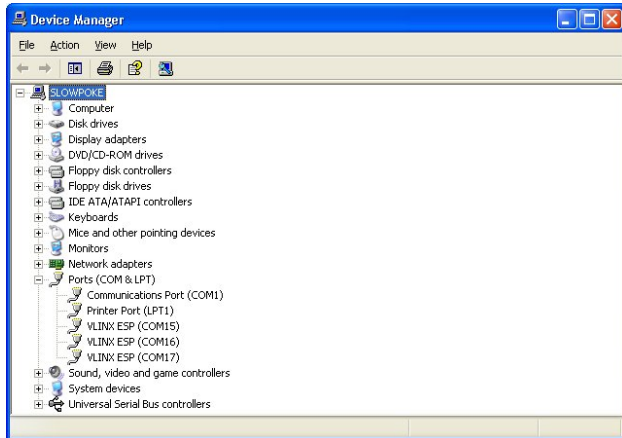

Figure 35. The Device Manager Window

**Step 4:** Highlight **ESP (COM #)** to be removed and click the **Action** tab at the top of window, then click **Uninstall**. A confirm **Device Removal** window will appear.

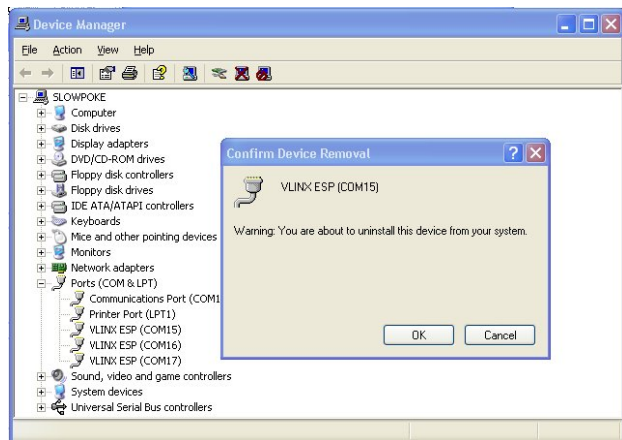

Figure 36. Confirm Device Removal

**Step 5:** Click **OK** to proceed.

The **ESP COM #** will be removed and the Device Manager window will refresh and display the remaining COM ports

## Chapter 8: UPGRADING THE SERIAL SERVER FIRMWARE

New **Serial Server** firmware updates may become available through the B&B Electronics website for installation into the server. The firmware can be uploaded using either a virtual COM port connection or hardware COM port connection.

### Downloading the Firmware

Make a folder to receive the firmware file. Download the compressed software file from the B&B Electronics website. Unzip or expand the file into the (.hex) format so it will be ready to upload to the Serial Server.

### Upgrading Via ESP Manager

The **ESP Manager** software can upload new firmware to the server using a direct PC connection via the ESR901 serial port, ESR902/904 Port 1, or using a virtual COM port.

#### Note:

*If connecting directly to a computer serial port, use a null modem cable between the Computer RS-232 port and the ESR901 serial port or ESR902 Port 1.*

### Preparing the Software

- Step 1:** In the **ESP Manager Serial Server List** window, double click the server to be upgraded. The **Server Properties** window will appear.
- Step 2:** If using a direct connection to upload the firmware to the **Serial Server**, set the baud rate to **115200** for the fastest possible upload.
- Step 3:** Set the **Serial Port** field to upgrade and click the **Update** button. (Ensure that the Run/Console switch is in the Run position.)
- Step 4:** Click **Yes** on the **vcomui** dialogue to restart the Serial Server.

### Upgrading the Firmware

- Step 5:** Double-click the **Firmware Upgrade** icon (or click the **Server** menu and **Firmware Upgrade**)
- Step 6:** In the **Upgrade** window, click **Browse**. The **Open** dialogue box will appear. Locate the folder on your PC that contains the firmware .hex file. **Select** the file and click **Open**. The Open dialogue box will disappear.
- Step 7:** In the **Upgrade** window select the serial port to be used in transferring the firmware.
- If connected directly from the PC to a Serial Server port it will typically be COM1 or COM2
  - If using a virtual COM port to upgrade via the network, identify the virtual COM number and address mapped to Port 1 on the Serial Server.
- Step 8:** Click **Upgrade**
- Step 9:** In the **Port Settings** window set the **Bits per second**, **Data bits**, **Parity** and **Stop bits** to the same values as set up in the **Server Properties** window. Click **OK**.

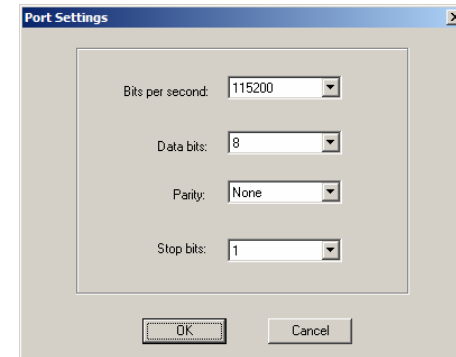

Figure 37. The Port Settings Window

- Step 10:** **Upgrade progress** will be shown until the **Upgrade finished!** message is shown. Click **OK**.

## Chapter 9: USING CONSOLE MODE

Before the **Serial Server** is installed on a LAN the **Console Mode** can be used to change the settings from the defaults. The Serial Server is shipped in the **RS-232 Mode**. Connect a crossover (null modem) cable between the COM port on the computer and the appropriate serial port on the Serial Server.

### Note:

See Chapter 5 for details of each Server Property Settings.

### Console Mode Setup

**Step 1:** Apply power to the Serial Server. The power and ready LED will light.

**Step 2:** Using a VT100 Terminal emulation program (typically **HyperTerminal** in Windows) open the computer COM port connected to the Serial Server (via an RS-232 crossover cable).

**Step 3:** In the HyperTerminal **Port Settings** window set:

- o Baud rate: 9600
- o Data bits: 8
- o Parity: None
- o Stop bits: 1
- o Flow control: None

Click **OK**

**Step 4:** Ensure the **Run/Console** switch is in the **Console** position.

**Step 5:** To view the **Configuration Menu**, press the **space bar**. The menu will appear within a few seconds.

### Navigating the Configuration Menus

There are six **Console Mode** screens: **Server**, **Network**, **Serial Mode**, **Operation**, **Monitor** and **Configuration**. **Tab**, **Back Space** and **arrow** keys can be used to highlight the desired function on the screen list. Pressing **Enter** moves the cursor to the first field with the current screen. The configuration fields can be changed by pressing **Enter** and selecting from the list that appears. The **Escape** key moves the cursor back to the screen list. Pressing the **Space Bar** refreshes the page.

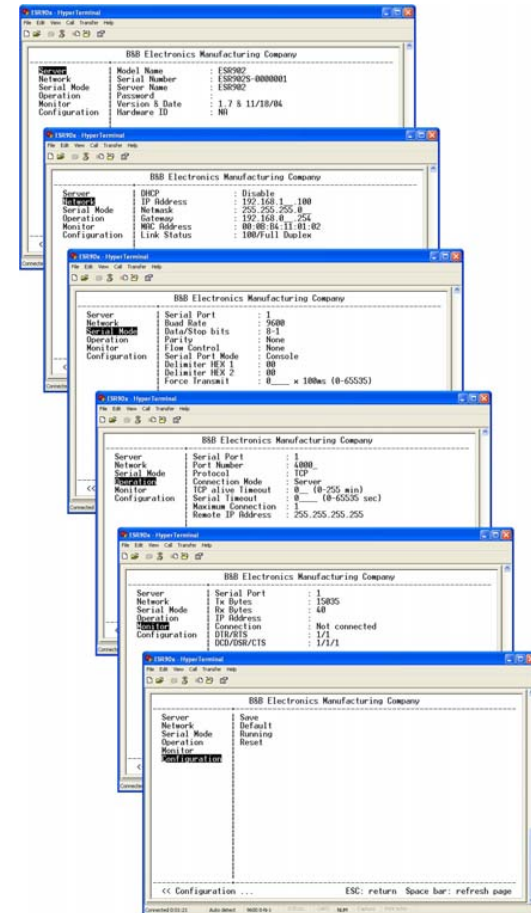

Figure 38. Console Mode Configuration Screens

**Step 5:** Once all the changes have been made move to the **Configuration** screen, select **Save** and press **Enter**.

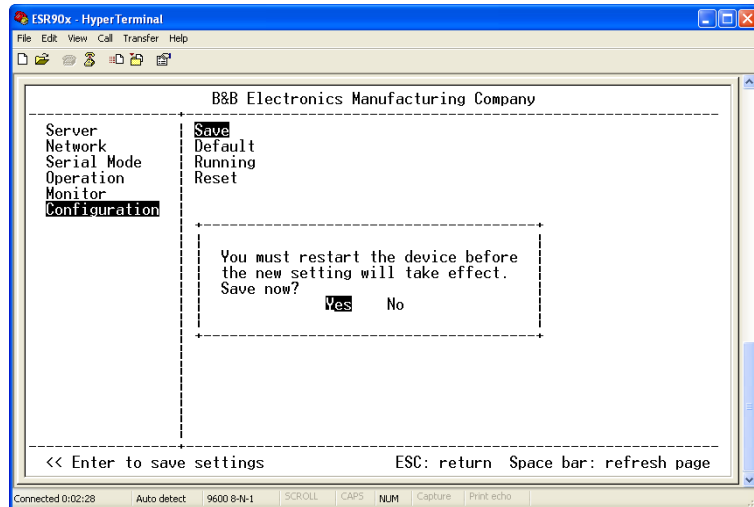

Figure 39. Saving and Restarting the Configuration

The restart message will appear.

**Step 6:** Select **Yes** to save changes. This is necessary to write the settings to the server.

### Using a Password

If a password is used it must be entered before the Configuration screen can be seen. If the server is accessed with a password but no changes are made, **Reset** to end before disconnecting.

## Chapter 10: USING THE WEB SERVER

The **Web Server** can be used to configure the Serial Server from any web browser software (such as Internet Explorer). Server properties can be set up using three browser pages.

### Note:

See Chapter 5 for details on Server Properties.

### Setting Server Properties

In Internet Explorer type the IP Address of the Serial Server into the address field near the top of the window and press the **Enter key**. The following window will appear:

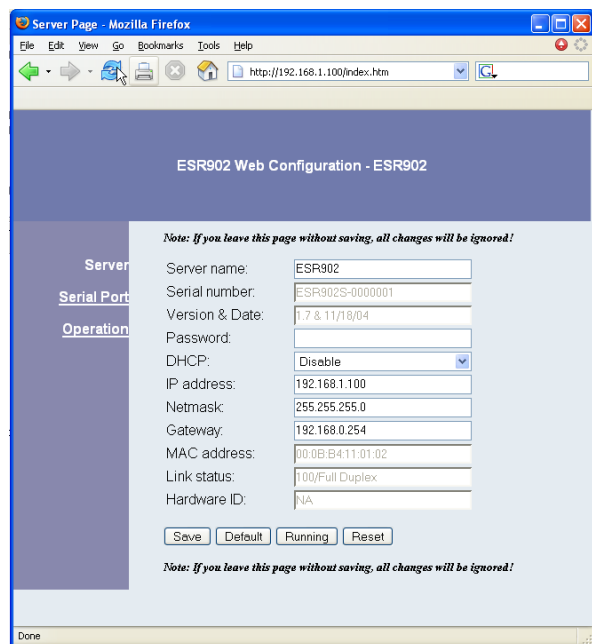

Figure 40. The Web Server Page

Navigate and change properties as required using the mouse and keyboard.

To change serial port properties, click **Serial Port** on the left side of the browser window. The following page will appear:

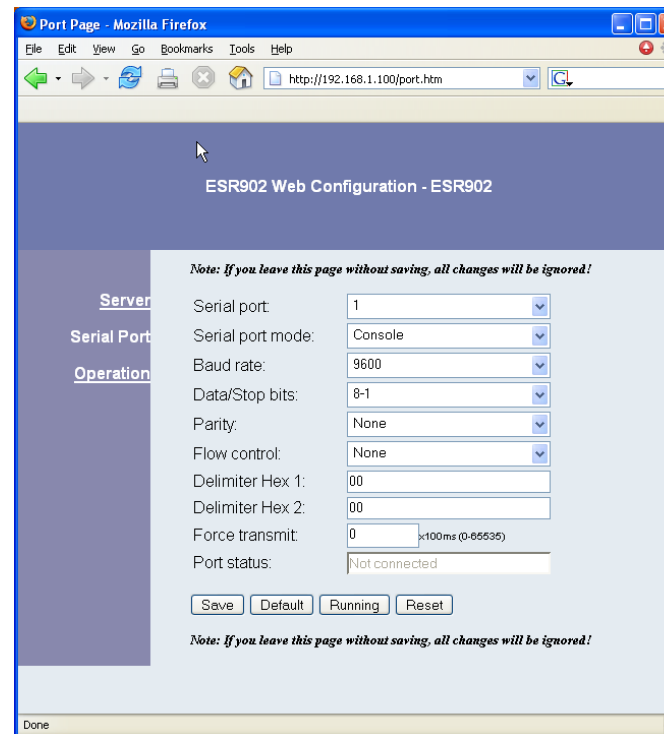

Figure 41. The Web Server Serial Port Properties Page

To change other operational properties, click **Operation** on the left side of the browser window. The following page will appear:

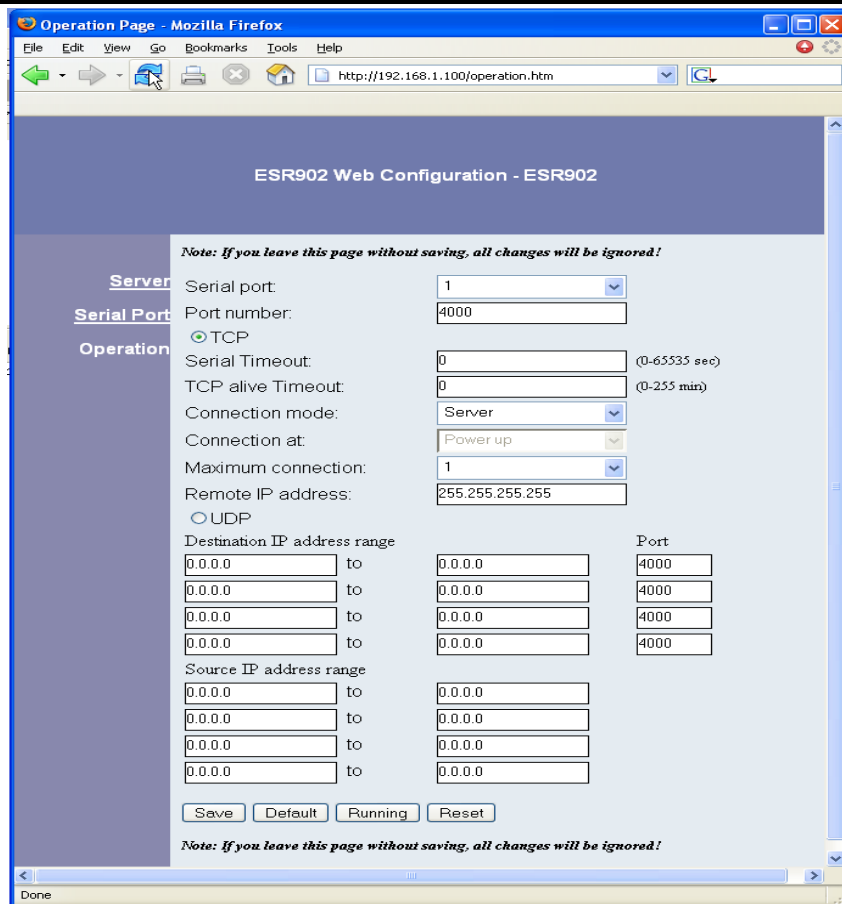

Figure 42. The Web Server Operation Page

Click **Save** to store changes to the Serial Server. Settings for each Port must be saved separately.

**Note:**

*If new property settings are not saved before leaving this page they will not take effect.*

Return to the main Server page by clicking on **Server** on the left side of the browser window.

## CHAPTER 11: USING TELNET

**Telnet** can be used to configure the Serial Server from any PC on the LAN. The **Telnet** window displays the same configuration information shown in **Console Mode** and allows server properties to be configured.

**Note:**

See Chapter 5 for details on Server Properties.

### Configuration Using Telnet

- Step 1:** Ensure the PC and Serial Server are connected to the LAN.
- Step 2:** Apply power to the Serial Server. The power and ready LED will light.
- Step 3:** Ensure Serial Server is in Run Mode. If the Run/Console switch is in the Console position, switch it to the Run position. The Serial Server will revert to the operational mode it was in before the switch was set to Console.
- Step 4:** From the **Desktop**, click **Start**, then **Run**. The Run dialogue box will open.
- Step 5:** Type in **Telnet** and the IP address of the Serial Server to be configured, then click **OK**.

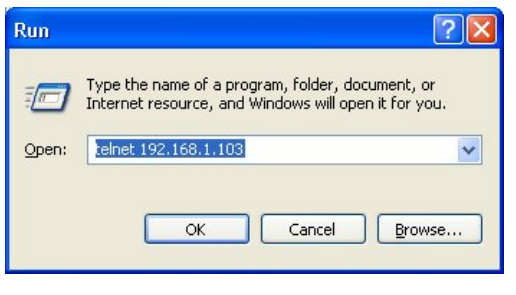

Figure 43. The Run dialogue box

**Note:**

The Serial Server must be in RS-232, RS-422 or RS-485 mode before you can Telnet to it and access the configuration screens. If it was last configured in Console mode you may not be able to access it using Telnet. In this case use ESP Manager, Console Mode or Web Server for configuration.

- Step 6.** The **Telnet** window will open (unless the server is still in Console mode) and the **Server** screen will appear.

## Navigating the Configuration Menu

There are six **Telnet** screens: **Server**, **Network**, **Serial Mode**, **Operation**, **Monitor** and **Configuration**. **Tab**, **Back Space** and **arrow** keys can be used to highlight the desired function on the screen list. Pressing **Enter** moves the cursor to the first field with the current screen. The configuration fields can be changed by pressing **Enter** and selecting from the list that appears. The **Escape** key moves the cursor back to the screen list. Pressing the **Space Bar** refreshes the page.

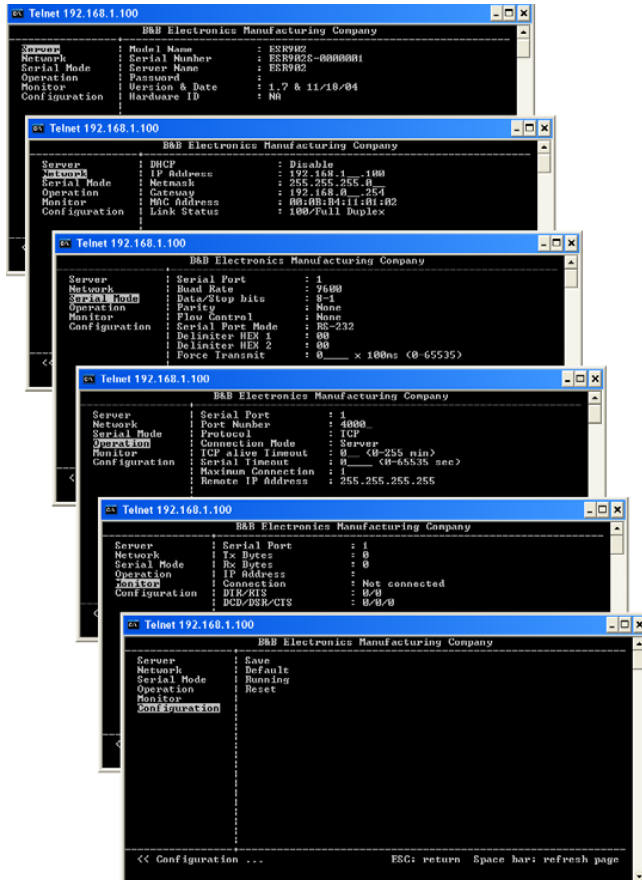

Figure 44. Telnet Configuration Screens

**Step 7:** Once all the changes have been made move to the **Save** field and select **Enter**. The restart message will appear.



Figure 45. Saving and Restarting the Configuration

**Step 8:** Select **Yes** to save changes. This is necessary to write the settings to the server. The Telnet window will disappear.

**Step 9:** To view the changes re-enter **Telnet** and re-establish communications. The configuration menu will appear and display the current settings.

## Chapter 12: ESR90x TECHNICAL DATA

<b>Hardware and Included Accessories</b>	<b>ESR901, ESR902 or ESR904 Serial Server modules</b> <b>Manual:</b> Paper copy of this manual, PDF available <b>CD-ROM disc:</b> VLINX ESP Manager and Virtual COM Driver software for Windows 98/ME/2000/XP/NT 4.0
<b>Dimensions</b>	<b>ESR901/ESR902:</b> 1.75 x 6.1 x 4.1 in (4.46 x 15.52 x 10.46 cm) <b>ESR904:</b> 1.75 x 7.1 x 4.1 in (4.46 x 18.03 x 10.46 cm)
<b>Power &amp; Environment</b>	<b>Power Supply Voltage Requirements:</b> 9V to 48 VDC or 8V to 24VAC <b>Power Consumption:</b> ESR901: 320mA @ 12VDC ESR902: 340 mA @ 12VDC ESR904: 360 mA @ 12VDC Power supply startup time $\leq$ 24ms <b>Operating Temperature:</b> -10 to 80 °C <b>Storage Temperature:</b> -20 to 85 °C <b>Humidity:</b> 5 – 98% R.H. <b>Approvals:</b> CE, FCC, IP30 case
<b>Indicators</b>	<b>Power:</b> Red LED <b>Link:</b> Yellow or green LED (10BaseT or 100 BaseTX) <b>Ready:</b> Flashing green LED
<b>Connectors</b>	<b>Ethernet:</b> Single RJ-45 female <b>Serial:</b> <b>ESR901:</b> one 9 pin D-type male (DB-9M) and one removable terminal block (connector selectable using DB-9/Terminal switch, interface type software selectable as RS-232, RS-422, RS-485H or 485F) <b>ESR902:</b> Two 9 pin D-type male (DB-9M), (interface type software selectable as RS-232, 422, RS-485H or RS-485F) <b>ESR904:</b> Four 9 pin D-type male (DB-9M) DTE, (interface type software selectable as RS-232, RS-422, RS-485H or 485F) <b>DC Power:</b> Removable four terminal screw-type terminal block

<b>Serial Interfaces</b>	<b>RS-232(DTE):</b> TXD, RXD, RTS, CTS, DTR, DSR, DCD, GND (ESR901 Terminal block option: TXD, RXD, RTS, CTS, GND) <b>RS-422:</b> TXDB(+), TXDA(-), RXDB(+), RXDA(-), RTS(+), RTS(-), CTS(+), CTS(-) and GND (ESR901 Terminal block option: (TXDB(+), TXDA(-), RXDB(+), RXDA(-), GND) <b>RS-485 H:</b> Data B (+), Data A (-) and GND <b>RS-485F:</b> TXDB(+), TXDA(-), RXDB(+), RXDA(-), and GND (ESR901 Terminal block option: (TXDB(+), TXDA(-), RXDB(+), RXDA(-), GND) <b>Baud Rate:</b> 110 bps to 230.4 k bps <b>Parity:</b> None, Even, Odd, Mark, Space <b>Data Bits:</b> 5, 6, 7 or 8 <b>Stop Bits:</b> 1, 1.5 or 2
<b>Memory</b>	<b>Serial Memory:</b> 8K byte per port <b>Network Memory:</b> 48K byte
<b>I/P Port Addresses</b>	<b>5300</b> Heartbeat & Configuration setting in TCP Mode (i.e. Pair Mode) <b>8888</b> Vlinx update <b>8890</b> Vlinx monitor <b>8889</b> Set configuration in UDP mode
<b>Network Communications</b>	<b>LAN:</b> 10/100 Mbps Auto-detecting 10 BaseT or 100 BaseTX
<b>Protocols</b>	TCP, IP, ARP, DHCP, Telnet, HTTP, UDP, ICMP
<b>Configuration Options</b>	<b>Console Mode:</b> Using RS-232 with VT100 emulation <b>Telnet Mode:</b> Using HyperTerminal with VT100 emulation <b>ESP Manager:</b> Using Windows 98/ME/2000/XP or NT software <b>Web Server:</b> Using Internet Explorer web browser
<b>Optional Accessories</b>	<b>232NM9</b> Null Modem Crossover Cable for DTE to DTE connection <b>ERS35</b> one-meter length of steel 35mm DIN Rail



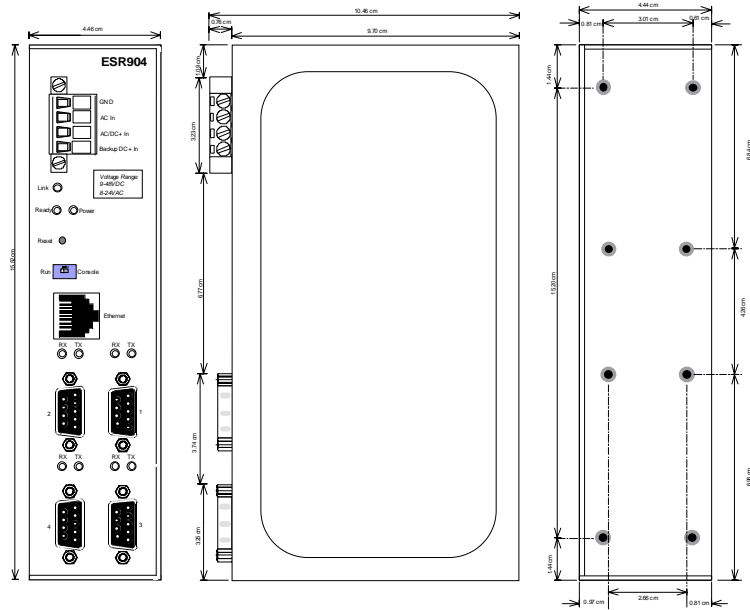

Figure 48. Dimensional Diagram of the ESR904

## APPENDIX A: RS-232 CONNECTIONS

### Serial Server DB-9 Pin-outs in RS-232 Mode

RS-232 Signal Name	DTE	RS-232	DB-9M Pin
Carrier Detect	In	DCD	1
Receive Data	In	RXD	2
Transmit Data	Out	TXD	3
Data Terminal Ready	Out	DTR	4
Signal Ground	---	GND	5
Data Set Ready	In	DSR	6
Request To Send	Out	RTS	7
Clear To Send	In	CTS	8
Ring Indicator	In	RI	9

Figure 49. RS-232 Connections in a DB-9 Connector

**ESR901 Terminal Block Pin-out in RS-232 Mode**

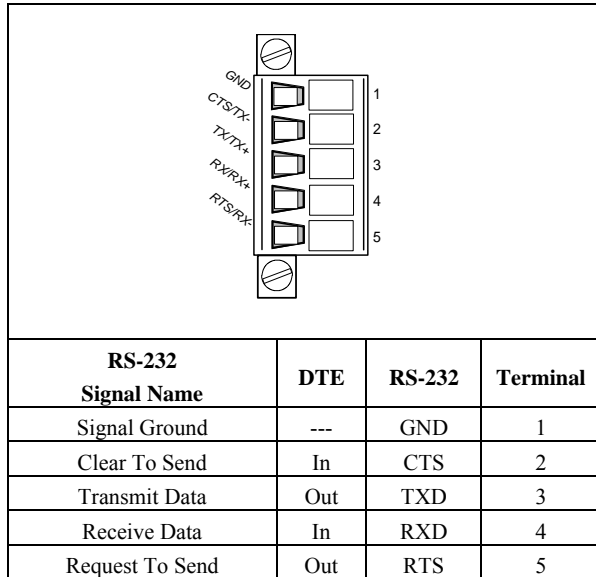

Figure 50. ESR901 Terminal Block Pin-out in RS-232 Mode

**APPENDIX B: RS-422/485 CONNECTIONS**

**ESR90x DB-9 Pin-out in RS-422 Mode**

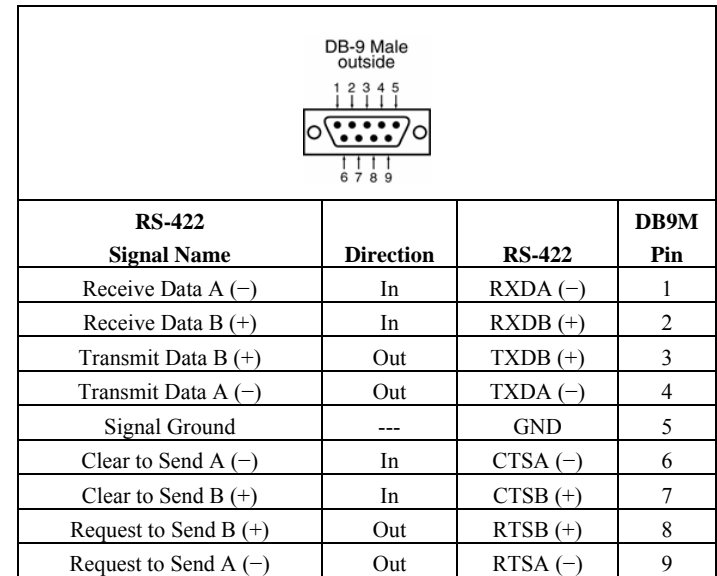

Figure 51. RS-422 Connections in a DB-9 Connector

**ESR901 Terminal Block Pin-out in RS-422 Mode**

Figure 52. ESR901 Terminal Block Pin-out in RS-232 Mode

In the RS-422 mode, TXD lines are outputs and RXD lines are inputs. Connect the Serial Server TXDB(+) line to the RXDB(+) line of the serial device, and the Serial Server TXDA(-) to the RXDA(-) of the serial device.

**If Flow Control is set for RTS/CTS**, connect the Serial Server RTSB(+) to CTSB(+) of the serial device and the Serial Server RTSA(-) line to the CTSA(-) of the serial device. Connect from the Serial Server CTSB(+) line to the RTSB(+) of the serial device and from the Serial Server CTSA(-) line to the RTSA(-) line of the serial device.

**If connecting to Receive Only** RS-422 devices, connect from the Serial Server TXDB(+) and TXDA(-) lines to the receive pairs on all serial devices.

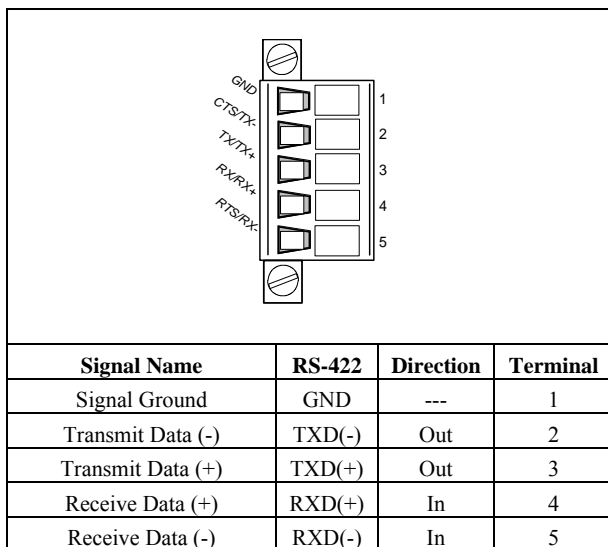
Ground is signal ground and provides a common mode reference for the RS-422 Receiver and Transmitters.

**APPENDIX C: RS-485 CONNECTIONS****ESR90x DB-9 Pin-out in RS-485H (two-wire, half duplex) Mode**

Figure 53. DB-9 Pin-out in RS-485 Mode

**ESR90x DB-9 Pin-out in RS-485F (four-wire, full duplex) Mode**

Figure 54. RS-422 Connections in a DB-9 Connector

**Note:**

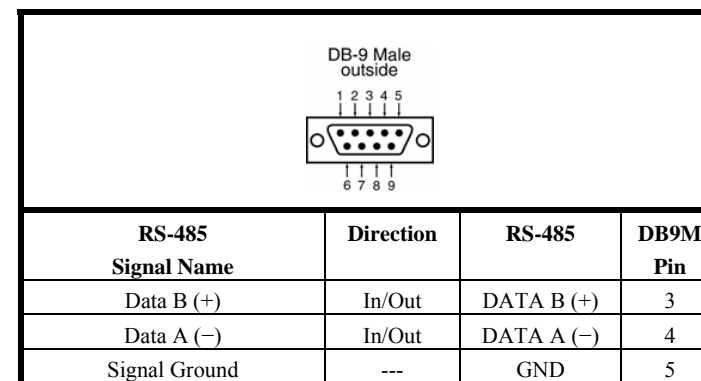
Some RS-485 devices are marked opposite the RS-485 standard, which defines the Data B line as positive relative to Data A during a Mark state before enabling the transmitter, and after transmitting before tri-stating. If an RS-485 device does not respond, try swapping the Data B and Data A lines.

**ESR901 Terminal Block Pin-out in RS-485F (four-wire, full duplex) Mode**

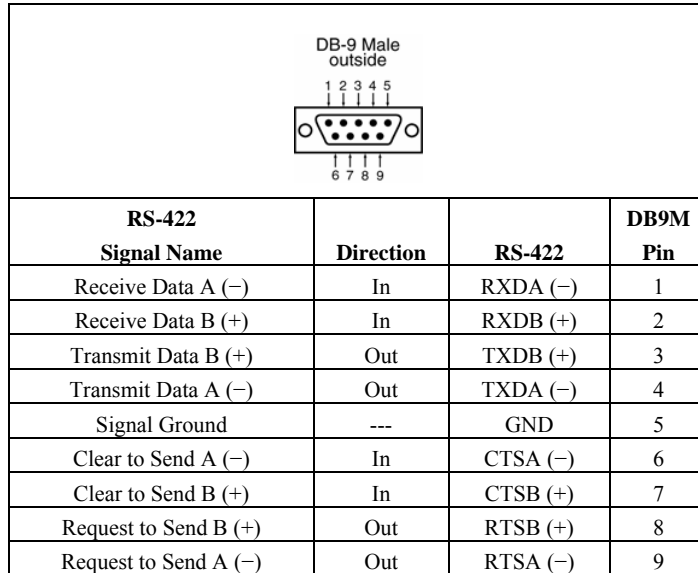
Figure 55. ESR901 Terminal Block Pin-out in RS-232 Mode

## APPENDIX D: NETWORK CONNECTIONS

### Standard Ethernet Cable RJ-45 Pin-out

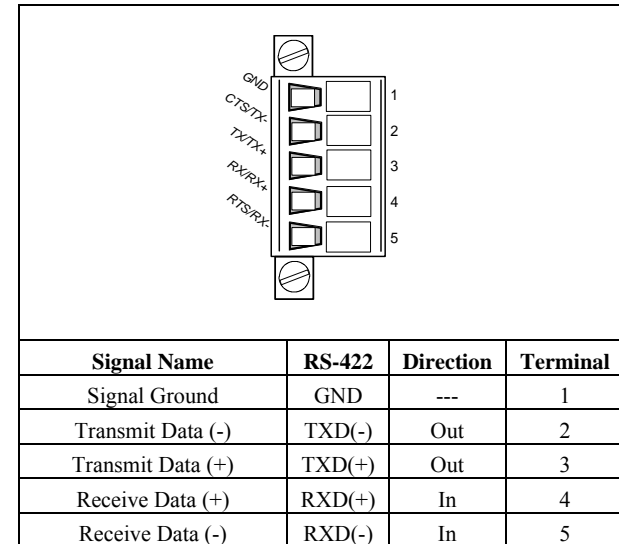
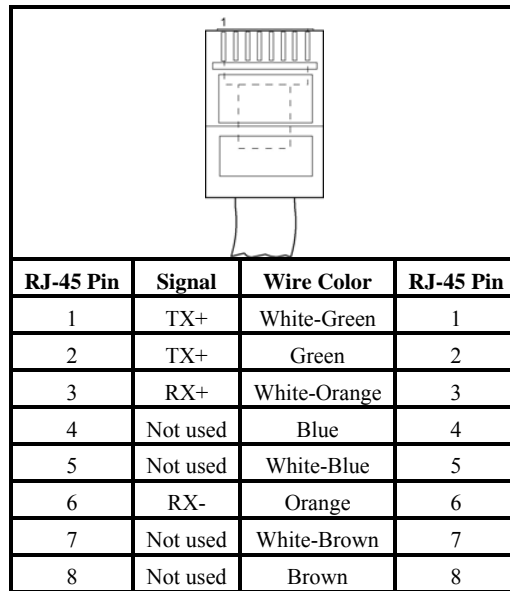

Figure 56. Pin-out for a Standard Ethernet Cable

### Crossover Ethernet Cable RJ-45 Pin-out

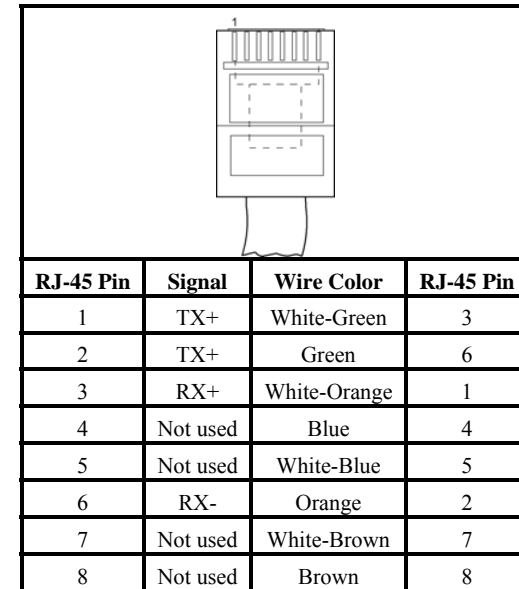

Figure 57. Pin-out for a Crossover Ethernet Cable



**International Headquarters**

B&B Electronics Mfg. Co. Inc.

707 Dayton Road

Ottawa, IL 61350 USA

**Phone** (815) 433-5100 -- **General Fax** (815) 433-5105

Website: [www.bb-elec.com](http://www.bb-elec.com)

**Sales** e-mail: [orders@bb-elec.com](mailto:orders@bb-elec.com) -- **Fax** (815) 433-5109

**Technical Support** e-mail: [support@bb.elec.com](mailto:support@bb.elec.com) -- **Fax** (815) 433-5104

**European Headquarters**

B&B Electronics Ltd.

Westlink Commercial Park

Oranmore, Co. Galway, Ireland

**Phone** +353 91-792444 -- **Fax** +353 91-792445

Website: [www.bb-europe.com](http://www.bb-europe.com)

**Sales** e-mail: [sales@bb-europe.com](mailto:sales@bb-europe.com)

**Technical Support** e-mail: [support@bb-europe.com](mailto:support@bb-europe.com)

© B&B Electronics – April 2005